

CHEVROLET C15A

No. 11 Cab PERSONNEL LORRY





(2H1 composite wood & steel body)



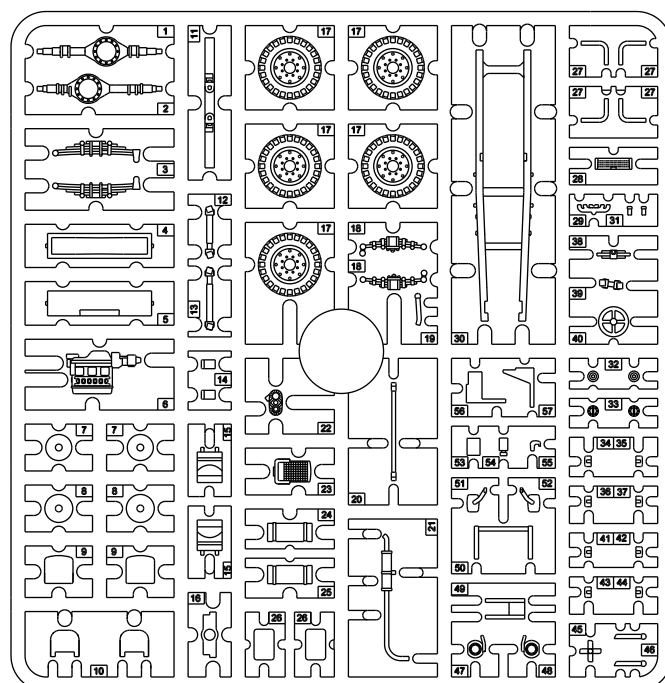
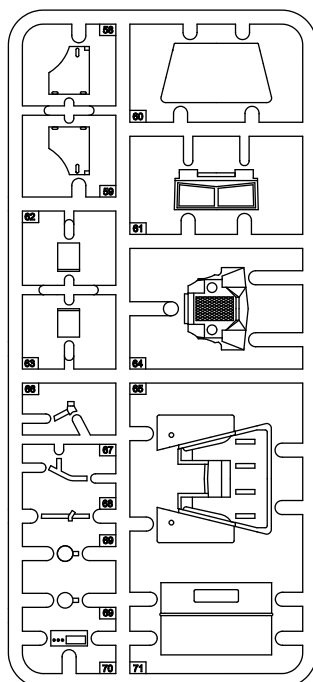
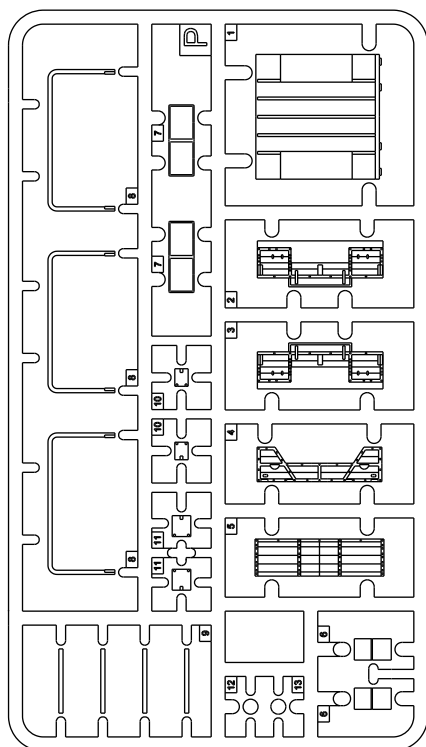



Cat. no. 72017

Scale 1/72



-  Element złożony we wcześniejszym etapie
Element assembled in previous step
-  Element po złożeniu w aktualnym etapie
Element after assembly in actual step
-  Kolor farby
Paint colour
-  Kalkomania
Decal

	Gunze Mr.Color	Model Master Acrylic	Humbrol	Vallejo MC
 A	C12	4728	155	887
 B	C137	4700	85	855
 C	C54	4736	158	--
 D	C119	4789	63	009

Project, design & artwork: Jarosław Leoniec
Research: IBG crew
Painting schemes research: Robert Sawicki

Przed montażem przeczytać instrukcję. Przestrzegać kolejności montażu podanego w instrukcji! Klej i farby nie wchodzą w skład zestawu.

Please read instruction before assembly. Obey sequence of assembly like in instruction. Glue and paints not included.

International Business Group
 ul. Benedykta Hertza 2
 04-603 Warszawa
 Poland

tel +48 22 8159150
 fax +48 22 8159151
 ibgsc@ibg.com.pl
 www.ibg.com.pl

**ETAP 1
STEP 1**

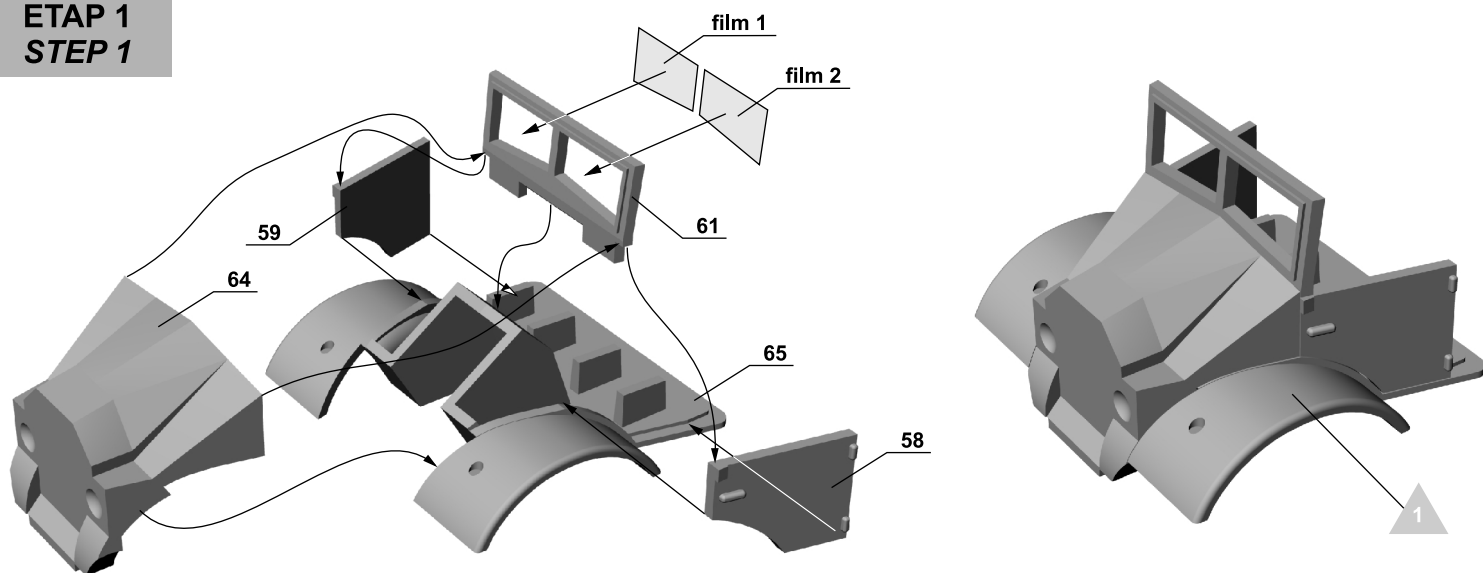

**ETAP 2
STEP 2**

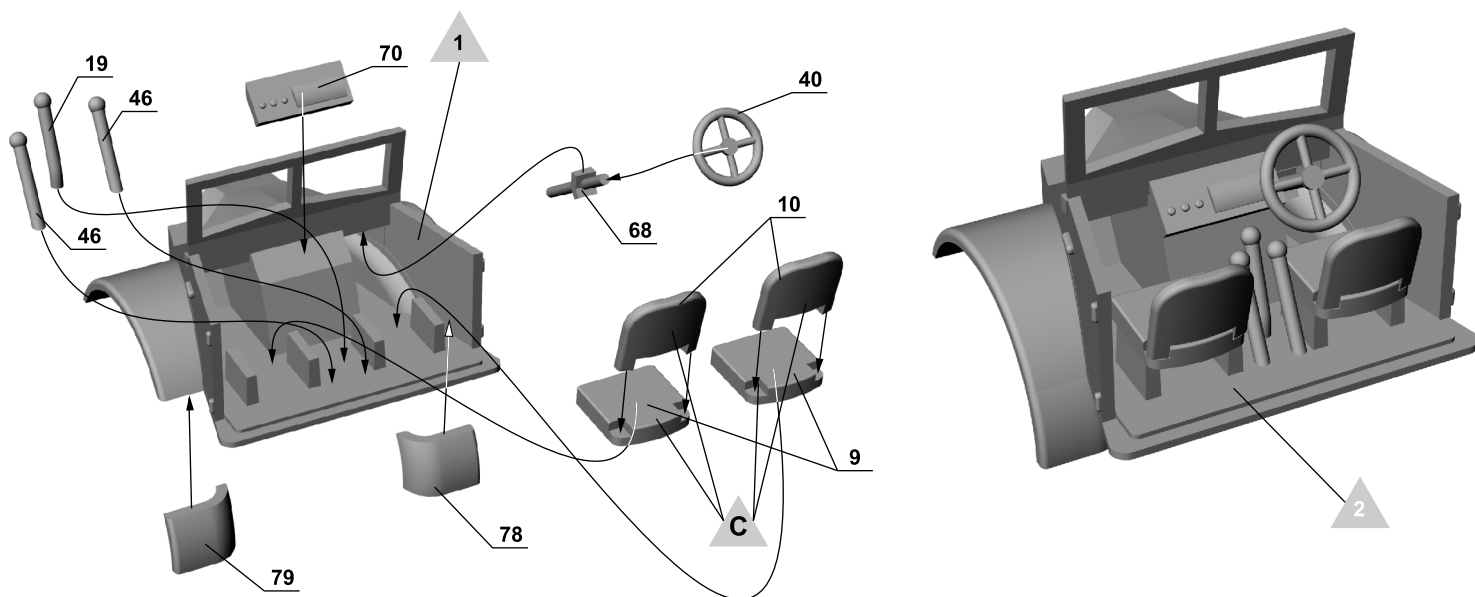

**ETAP 3
STEP 3**

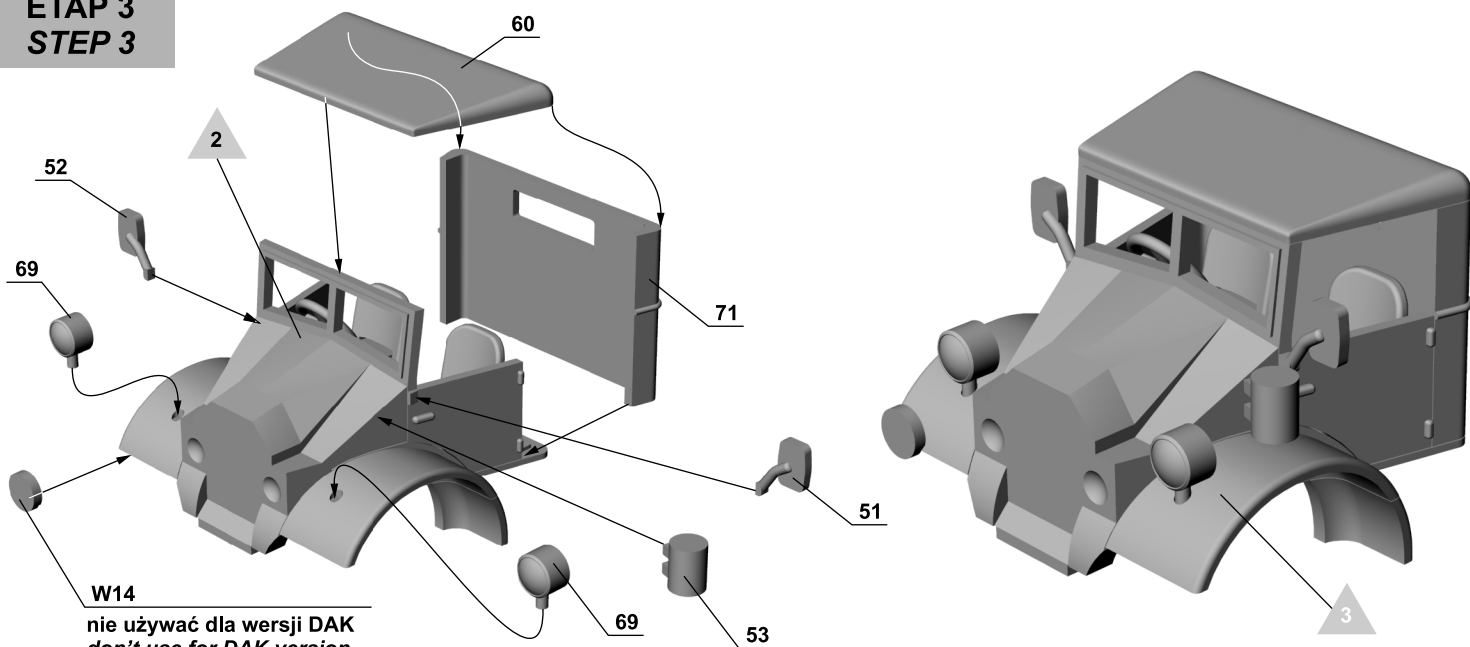

**ETAP 4
STEP 4**

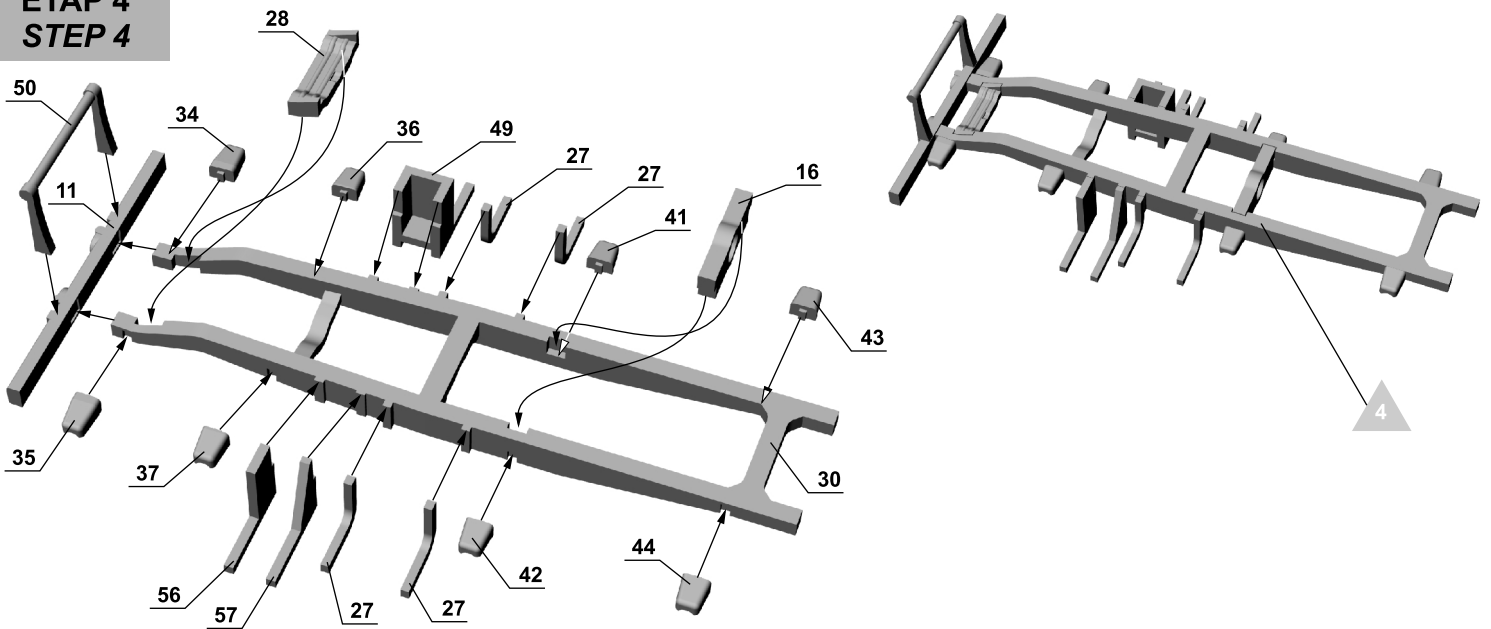

**ETAP 5
STEP 5**

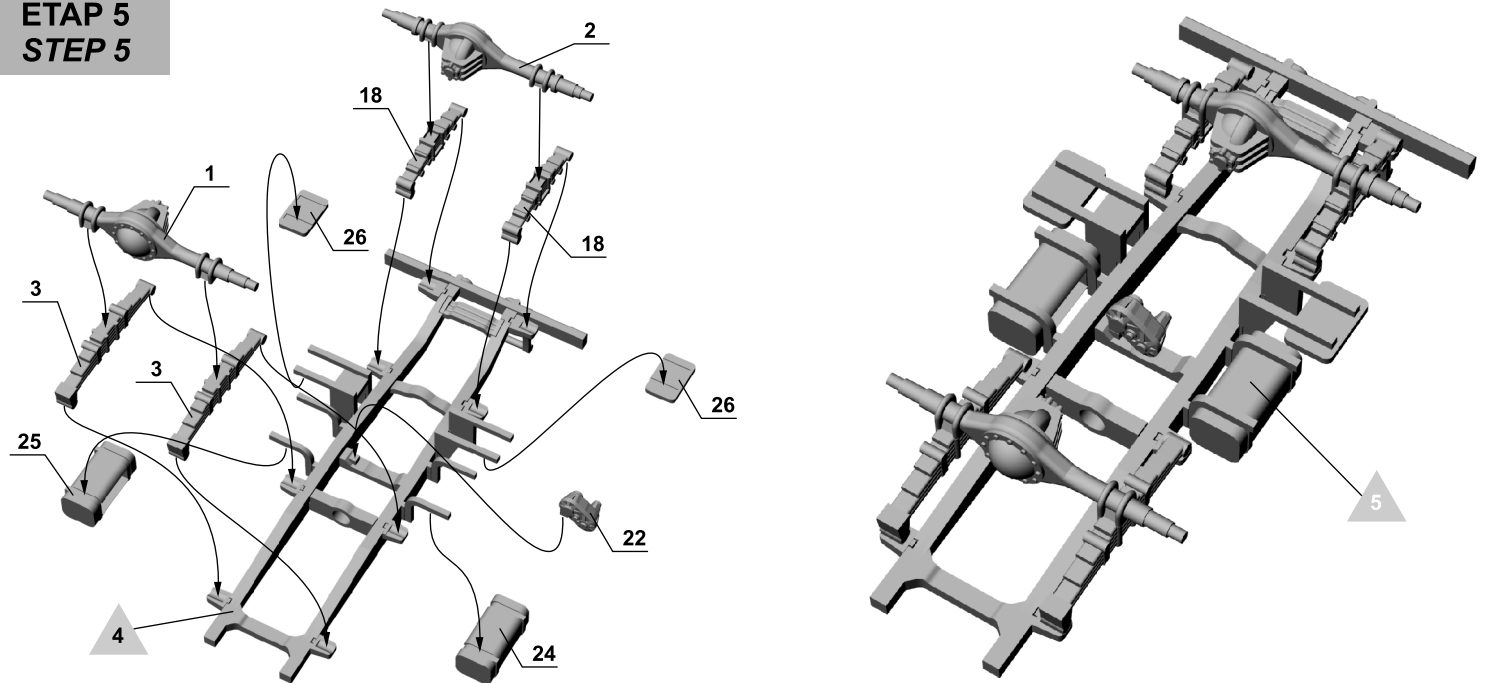

**ETAP 6
STEP 6**

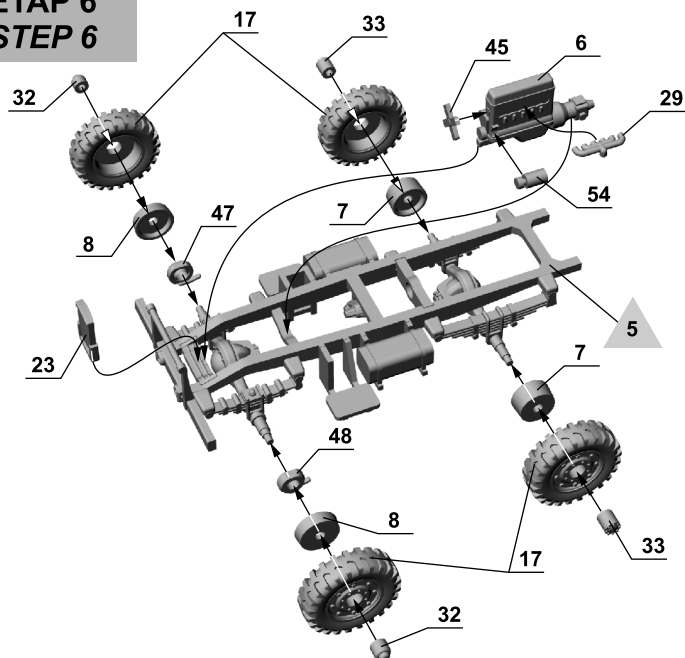

Detale 47 i 48 przewiercić fi 1,7 mm
Details 47 & 48 drill fi 1,7 mm

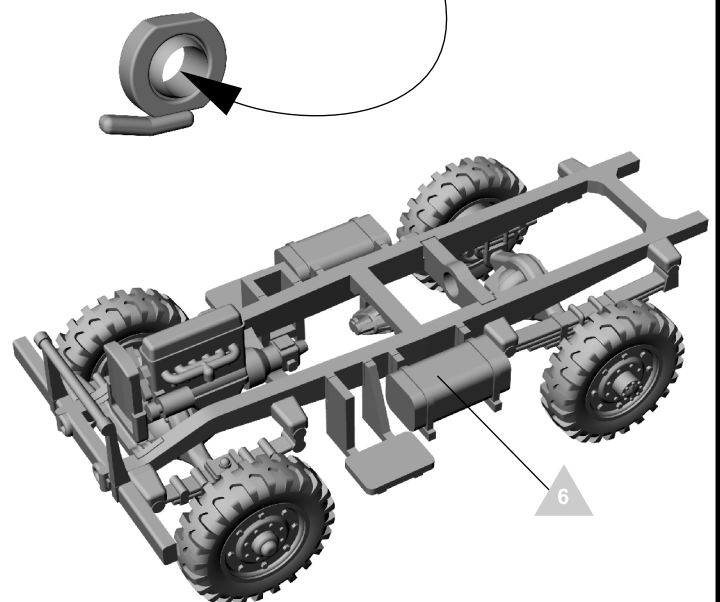

**ETAP 7
STEP 7**

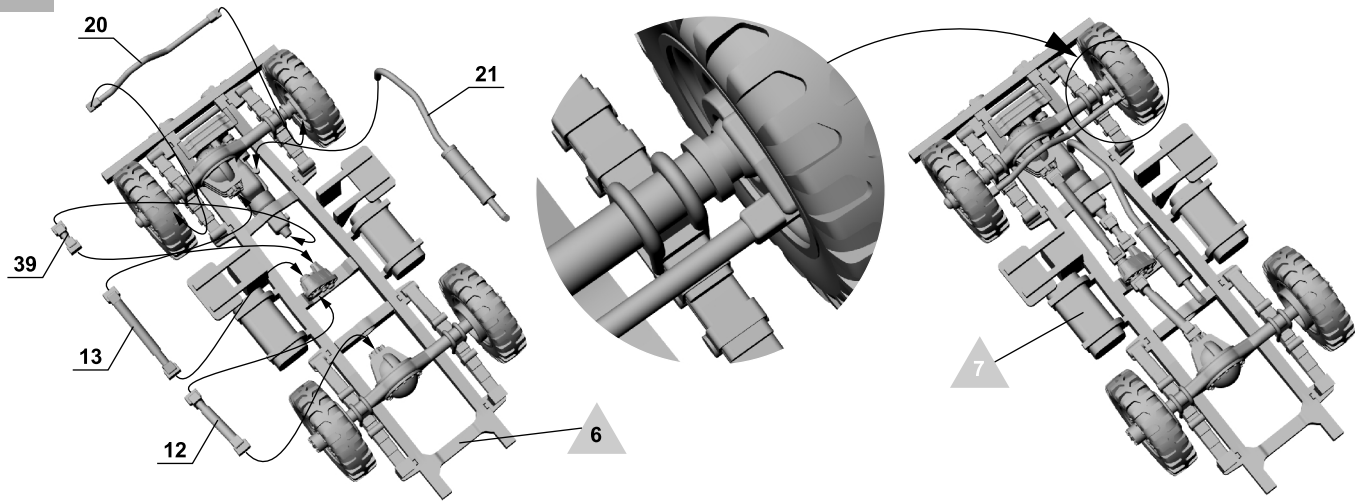

**ETAP 8
STEP 8**

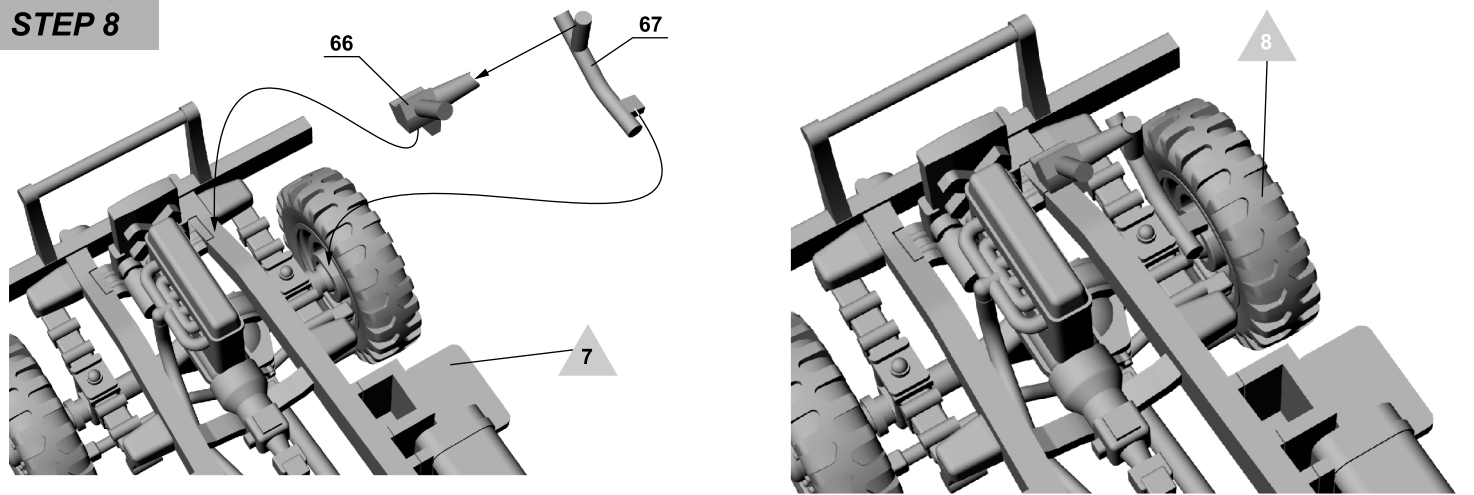

**ETAP 9
STEP 9**

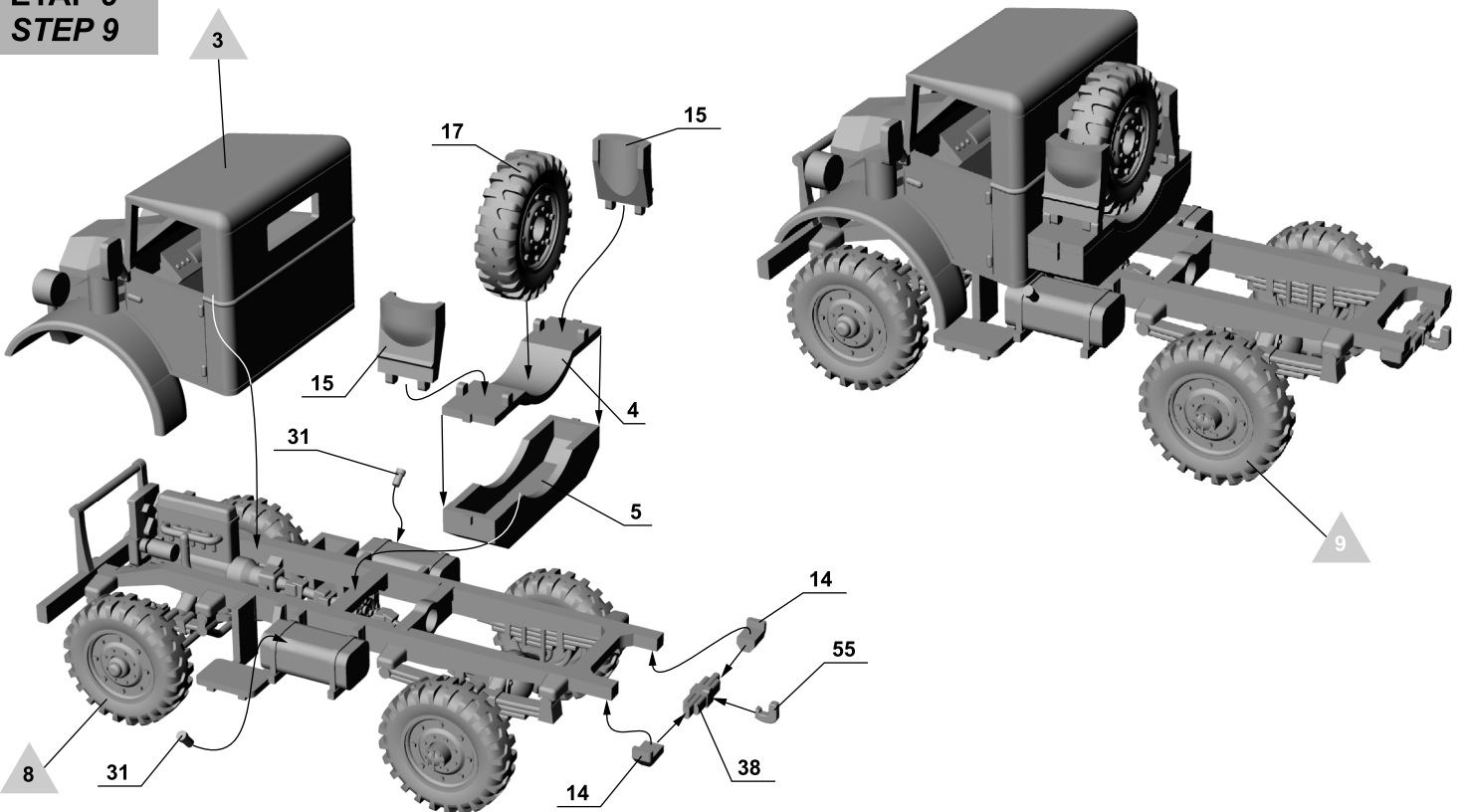

ETAP 10
STEP 10

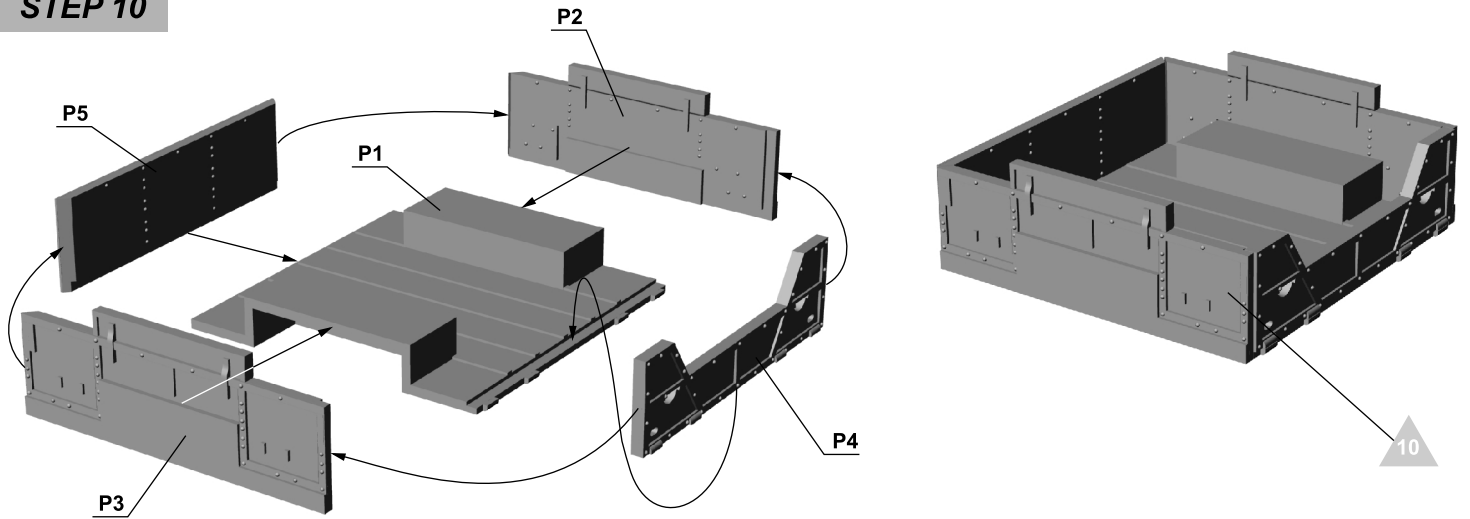

ETAP 11
STEP 11

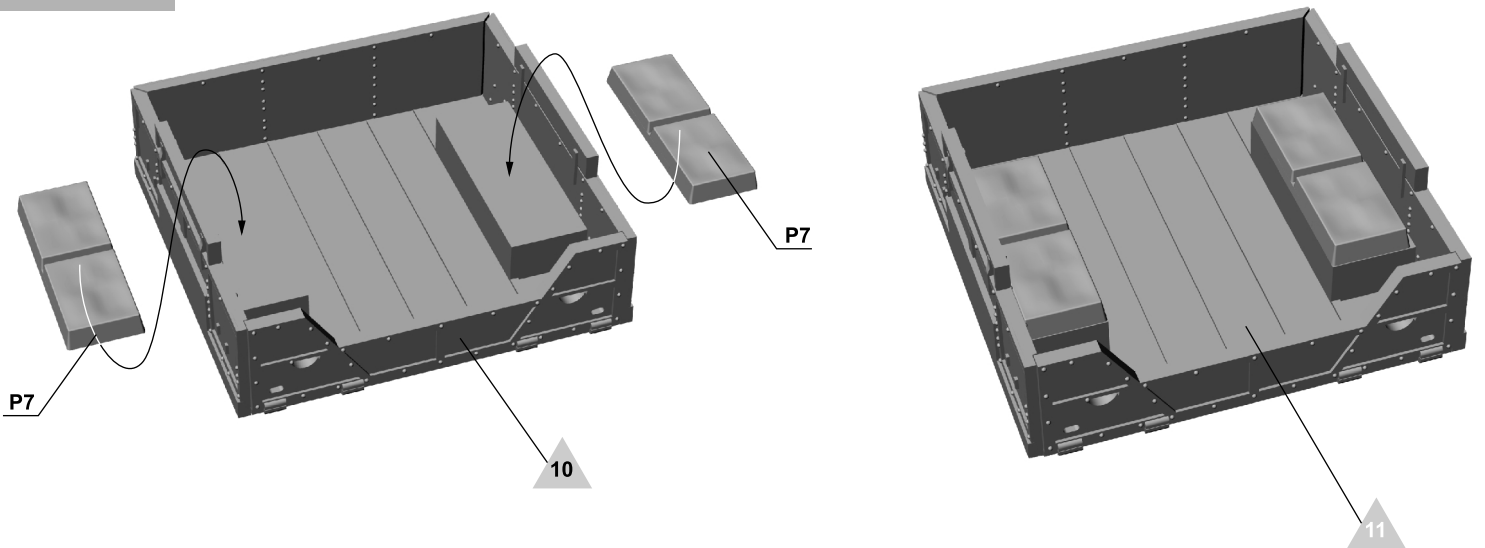

ETAP 12
STEP 12

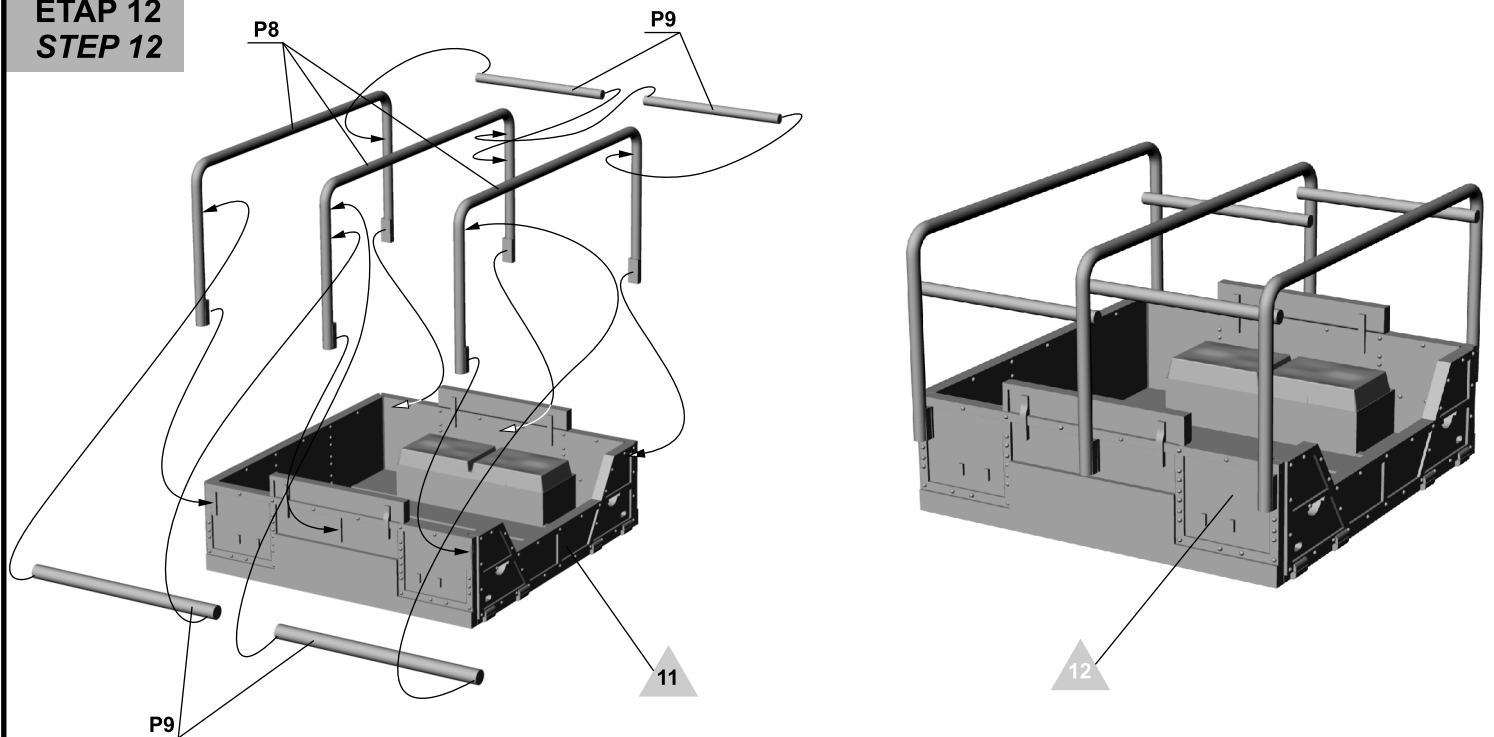

ETAP 13
STEP 13

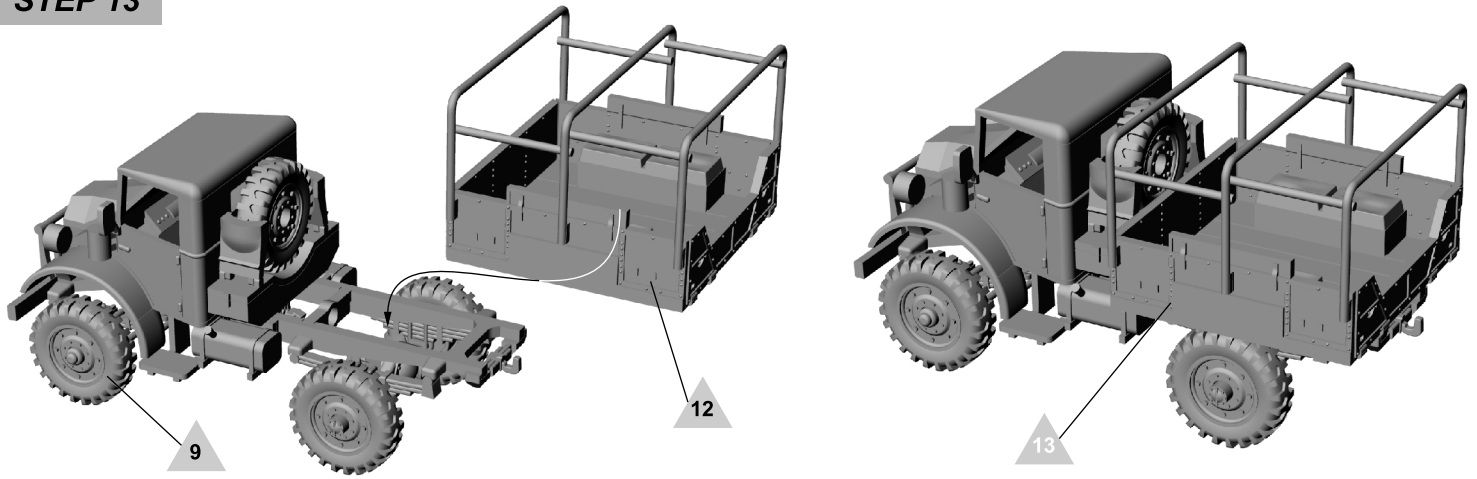

ETAP 14
STEP 14

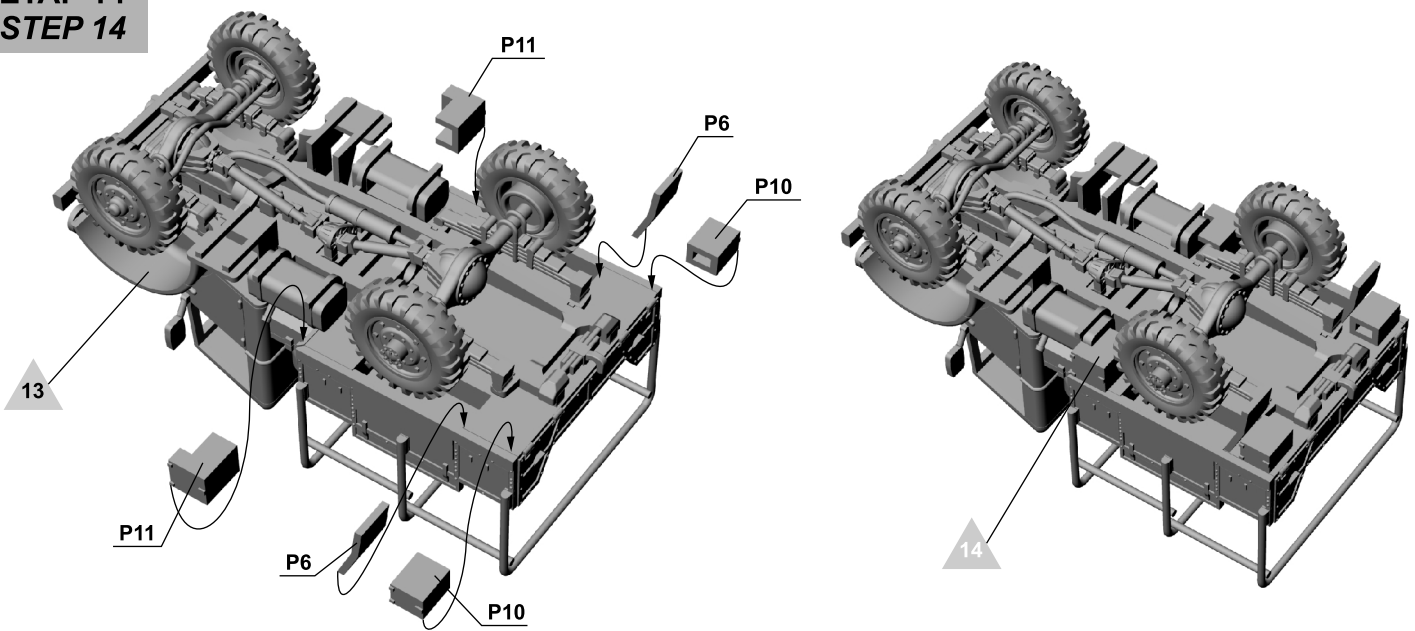

WYKONANY MODEL
FINISHED MODEL

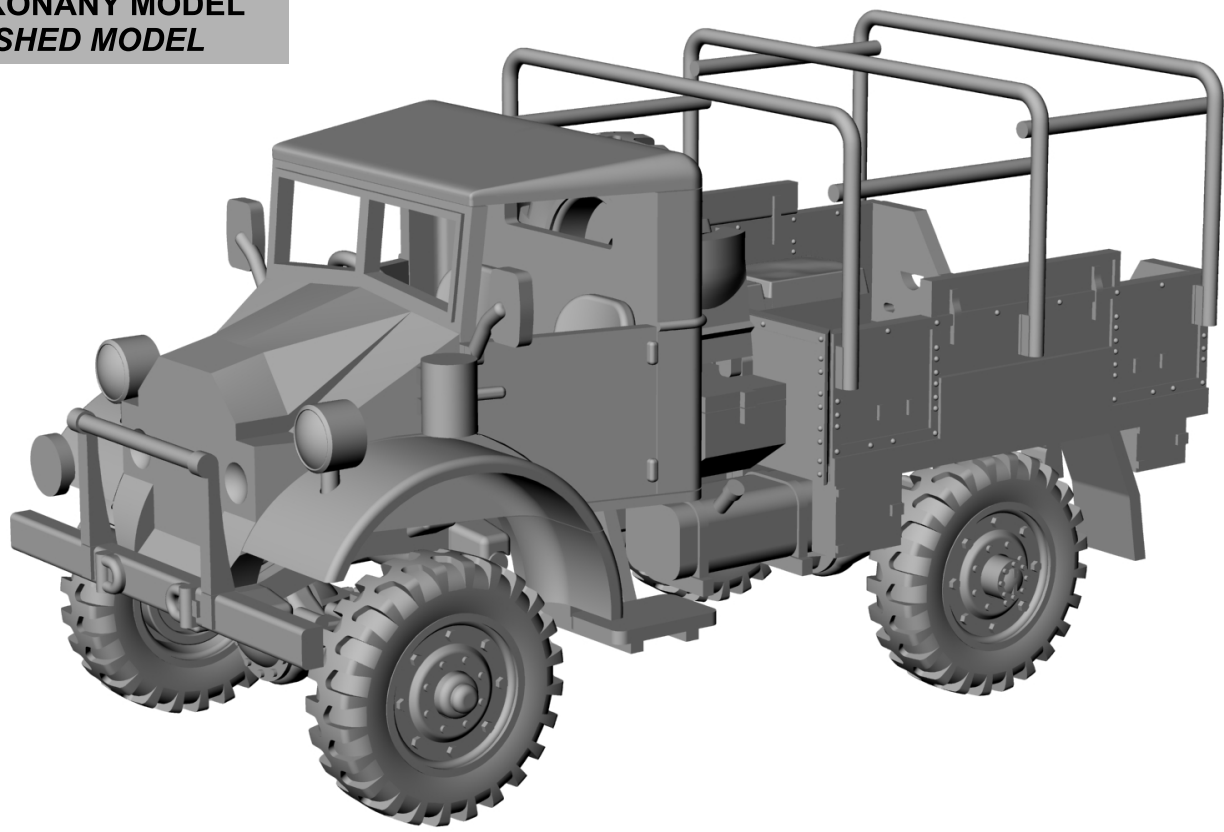

**MALOWANIE I KALKOMANIE
COLOURS AND DECALS**

**CHEVROLET C15A No. 11 Cab Personnel Lorry
(2H1 composite wood & steel body)
z 1szej Kanadyjskiej Dywizji Piechoty,
Europa Zachodnia 1944
CHEVROLET C15A No. 11 Cab Personnel Lorry
(2H1 composite wood & steel body)
from 1st Canadian Infantry Division,
West Europa 1944**

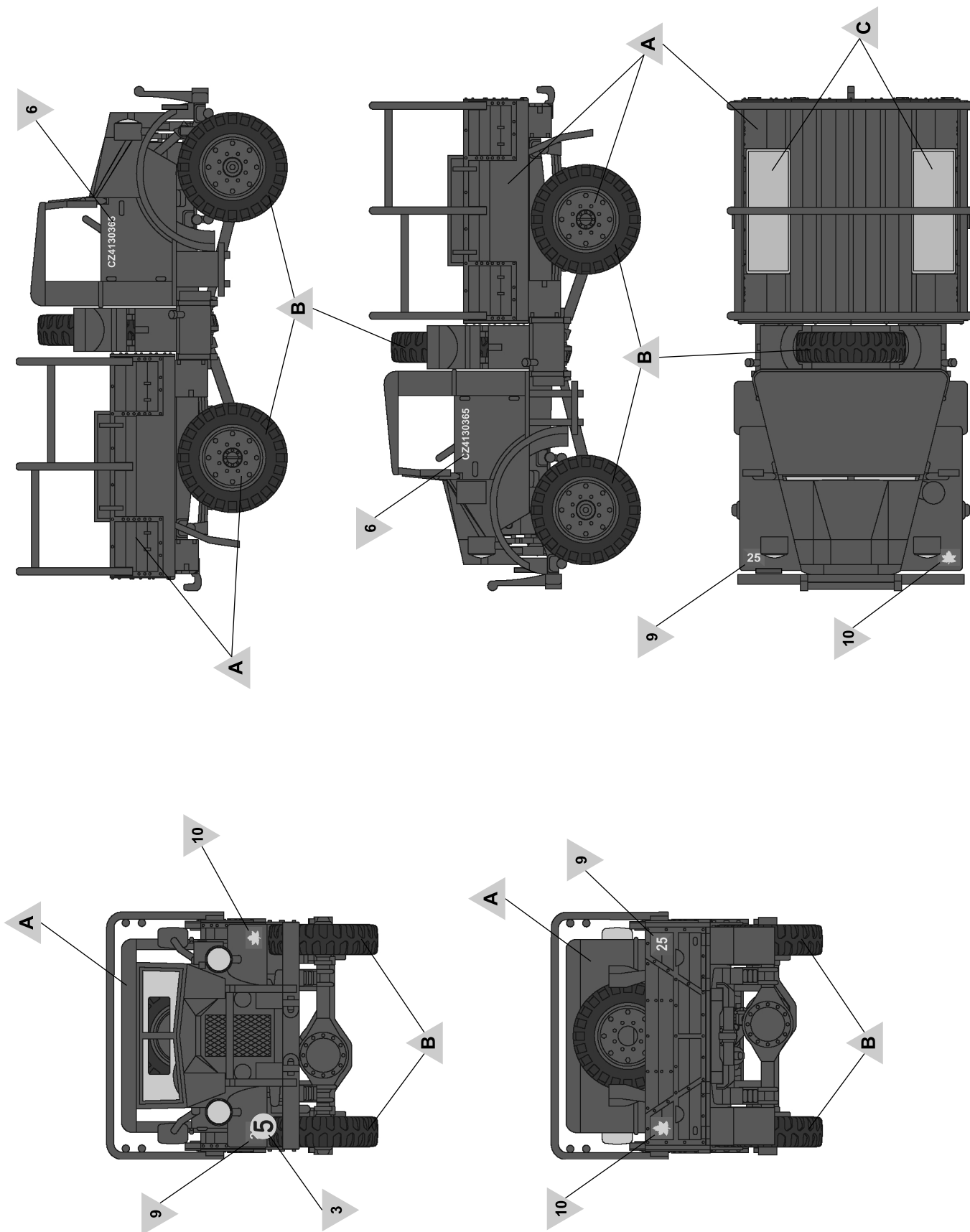

**MALOWANIE I KALKOMANIE
COLOURS AND DECALS**

CHEVROLET C15A No. 11 Cab Personnel Lorry
(2H1 composite wood & steel body)
z 4go Szpitala Wojennego Polskiej Armii na
Wschodzie, Środkiy Wschód 1943
CHEVROLET C15A No. 11 Cab Personnel Lorry
(2H1 composite wood & steel body)
*from 4th War Hospital Polish Army on the East,
Middle East 1943*

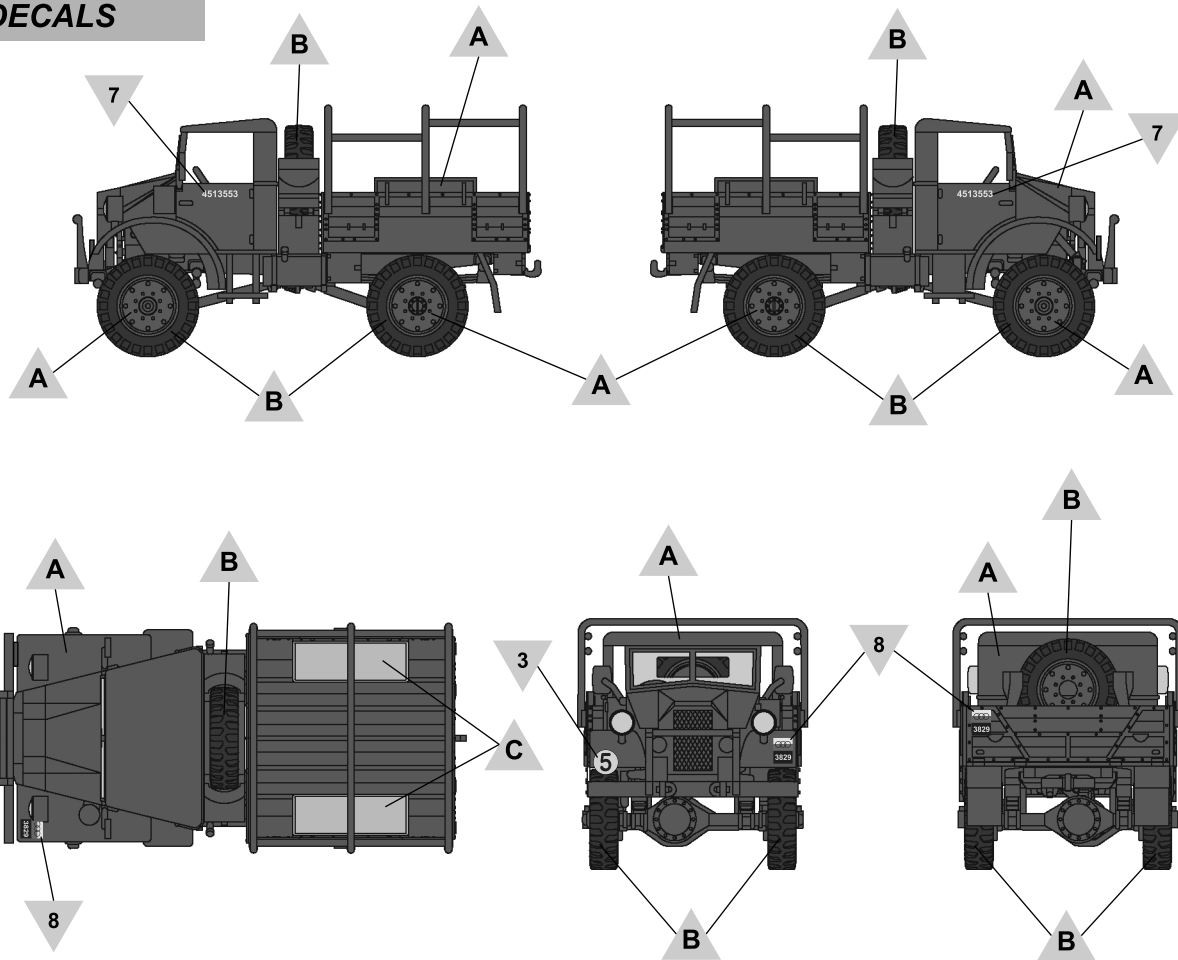

CHEVROLET C15A No. 11 Cab Personnel Lorry
(2H1 composite wood & steel body)
zdobyty i używany przez Deutsches Afrika Korps,
Północna Afryka 1942
CHEVROLET C15A No. 11 Cab Personnel Lorry
(2H1 composite wood & steel body)
*captured and used by Deutsches Afrika Korps,
North Africa 1942*

