

# UNIVERSAL CARRIER I Mk II

## Mortar Carrier













Cat. no. 72025

Scale 1/72



Project, design & artwork: Jarosław Leoniec  
Research: Jarosław Leoniec & IBG crew

-  Element złożony we wcześniejszym etapie  
*Element assembled in previous step*
-  Element po złożeniu w aktualnym etapie  
*Element after assembly in actual step*
-  Wersja do wyboru  
*Version to choose*
-  Kalkomania  
*Decal*
-  Kolor farby  
*Paint colour*
-  Część nie do użycia  
*Part not for use*

		Gunze Mr.Color	Model Master Acrylic	Humbrol	Valleyo MC
black		C002	4695	21	861
wood		C043	4673	110	846
gunmetal		C104	4681	53	863
olive drab		C038	4842	155	889
leather		C019	4674	62	843

Przed montażem przeczytać instrukcję. Przestrzegać kolejności montażu podanego w instrukcji! Klej i farby nie wchodzi w skład zestawu.

Uwaga! Zdecydowanie sugerujemy użycie bardzo rzadkiego kleju - Tamiya Extra Thin Cement jest najlepszym wyborem. Montaż gąsienicy należy przeprowadzić dość szybko bo sklejana gąsienica zachowuje miękkość przez kilkanaście minut i można ją wtedy wyginać i dopasowywać.

*Please read instruction before assembly. Obey sequence of assembly like in instruction. Glue and paints not included.*

*Attention! We strongly suggest using of very thin glue - Tamiya Extra Thin Cement will be the best choice. Assembly of track please make in short period of time, because assembled track is still soft and can be fitted and bended.*

Ramka M / Frame M

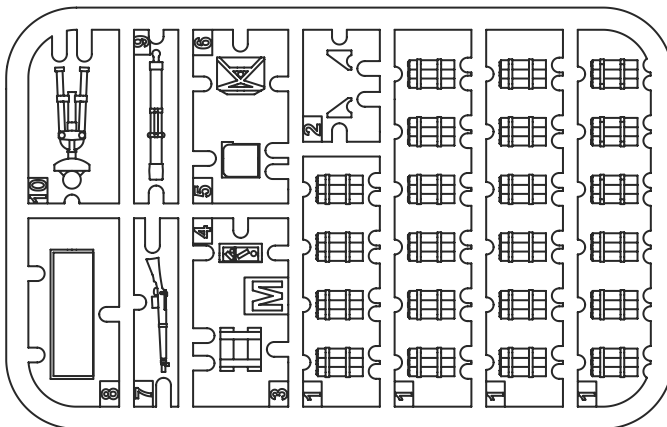

Ramka Z / Frame Z

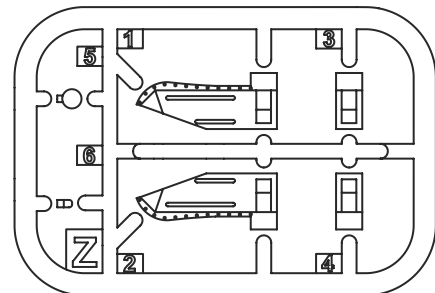

International Business Group  
ul. Benedykta Hertza 2  
04-603 Warszawa  
Poland

tel +48 22 8159150  
fax +48 22 8159151  
ibgsc@ibg.com.pl  
www.ibg.com.pl

Ramka bez oznaczenia literowego / No letter frame

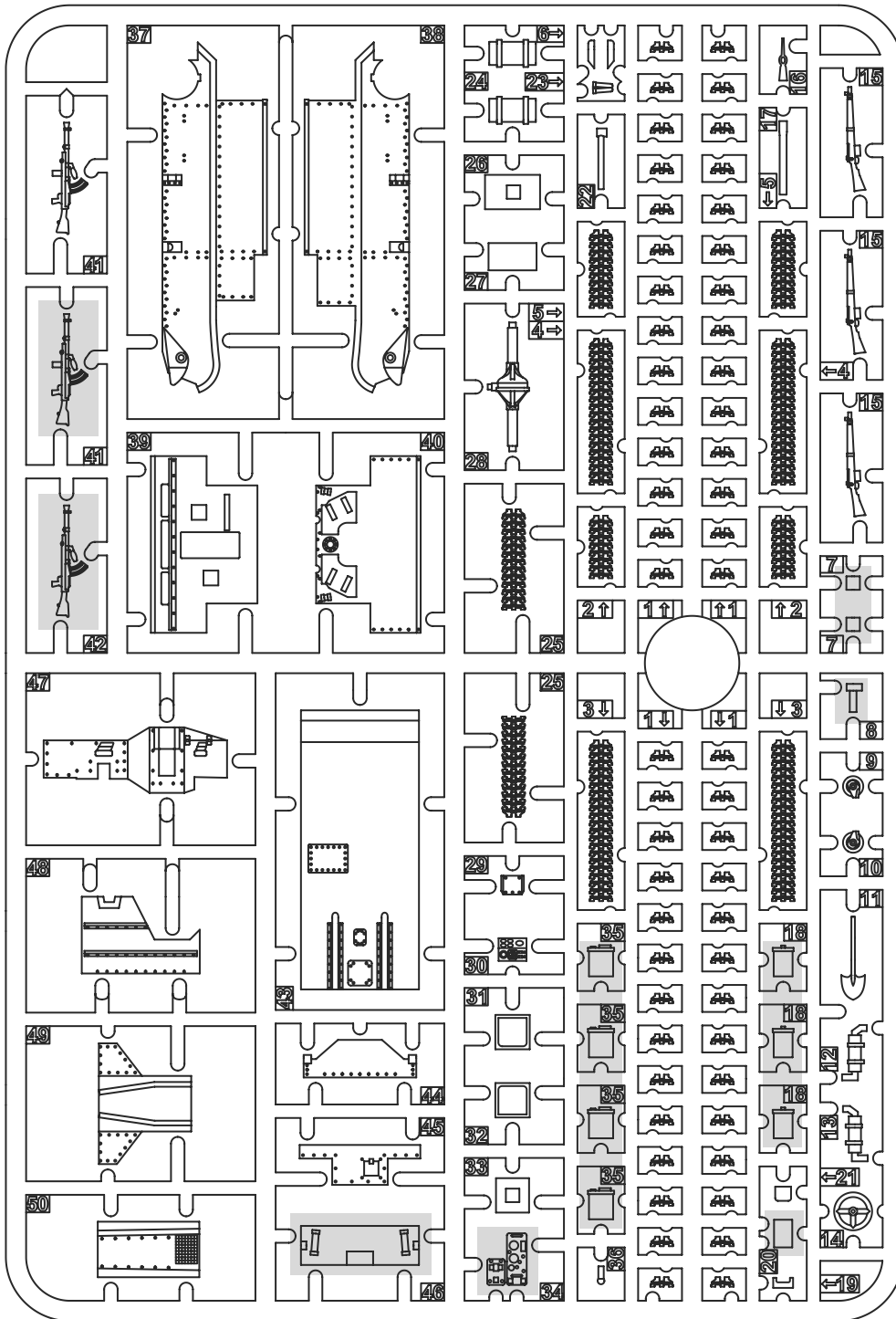

Ramka X / Frame X

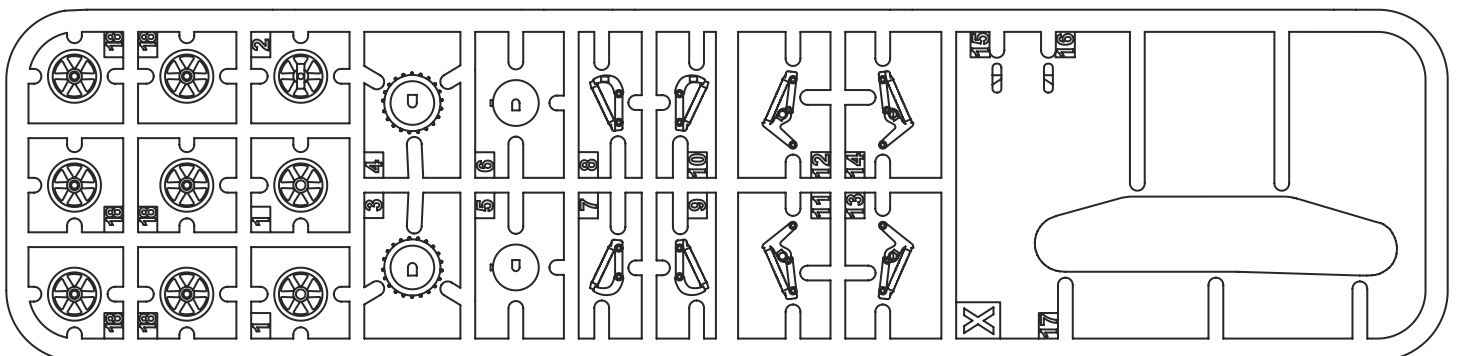

International Business Group  
 ul. Benedykta Hertza 2  
 04-603 Warszawa  
 Poland

tel +48 22 8159150  
 fax +48 22 8159151  
 ibgsc@ibg.com.pl  
 www.ibg.com.pl

## ETAP 1 Montaż gąsienicy STEP 1 Track assembly

**Uwaga! Zdecydowanie sugerujemy użycie bardzo rzadkiego kleju - Tamiya Extra Thin Cement jest najlepszym wyborem. Należy zmontować dwie gąsienice.**  
**Attention! We strongly suggest using of very thin glue - Tamiya Extra Thin Cement will be the best choice. Two tracks have to be assembled.**

- I** Montuj gąsienicę na twardej, płaskiej powierzchni. Posmaruj odrobiną kleju i zsuń dołączenia używając dwóch igieł.  
*Assembly track on hard, flat surface. Add some glue and slide together using two needles.*

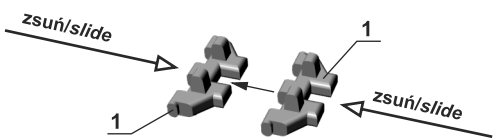

- II** Dociśnij do powierzchni dla wyrównania.  
*Press to flat surface to align.*

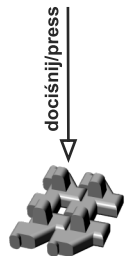

- III** Analogicznie dodaj kolejne ogniwa.  
*Analogically add two track links.*

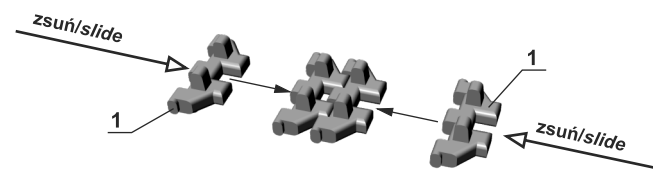

- IV** Dociśnij do powierzchni dla wyrównania.  
*Press to flat surface to align.*

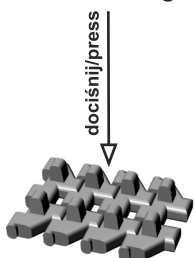

- V** Złóż dwa odcinki - z 10 ogniw i z 11 ogniw.  
*Assembly two segments - 10 track links and 11 track links.*

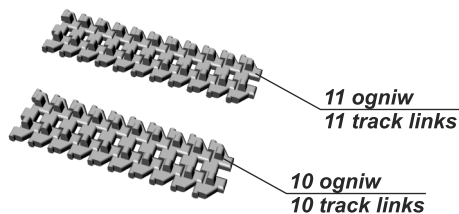

- VI** Zegnij i dopasuj oba odcinki używając wzornika.  
*Bend and fit both segments using pattern.*

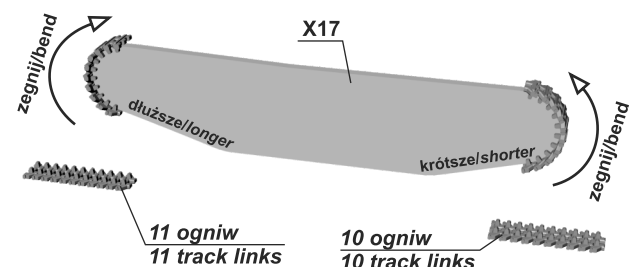

- VII** Dopasuj i sklej pierwszą część gąsienicy używając wzornika.  
*Fit and glue first part of track using pattern.*

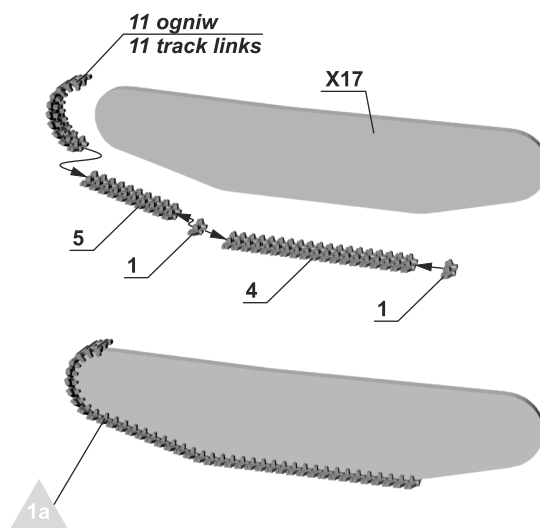

- VIII** Dopasuj i sklej drugą część gąsienicy używając wzornika.  
*Fit and glue second part of track using pattern.*

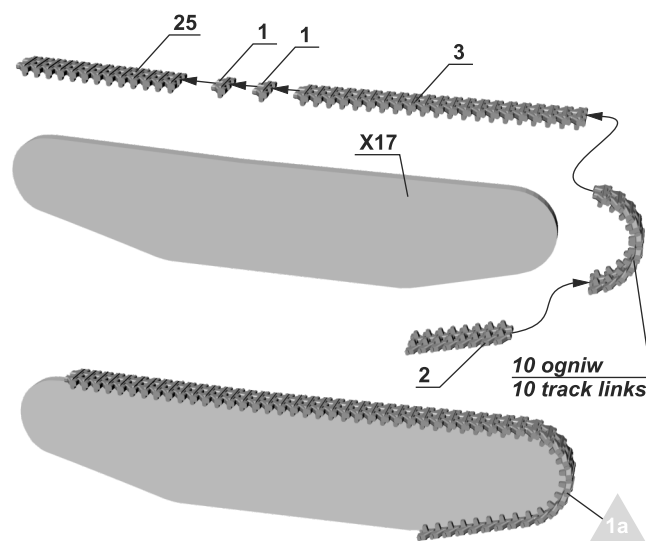

- IX** Sprawdź dopasowanie obu części używając wzornika. Nie sklejać ich razem!  
*Check fitting both parts of track using pattern. Don't glue them together!*

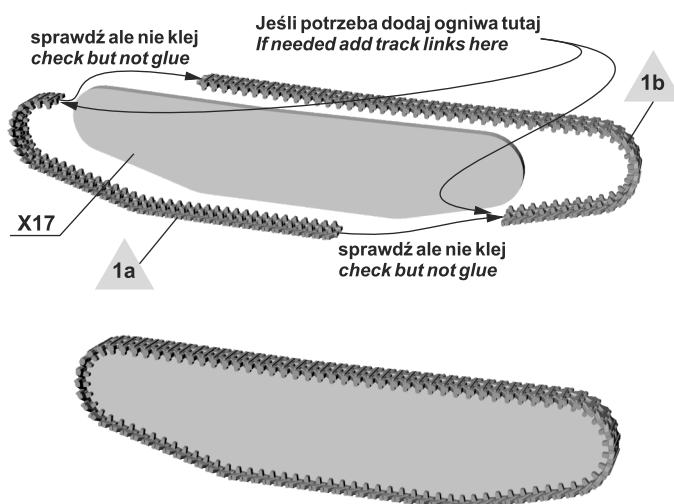

**ETAP 2  
STEP 2**

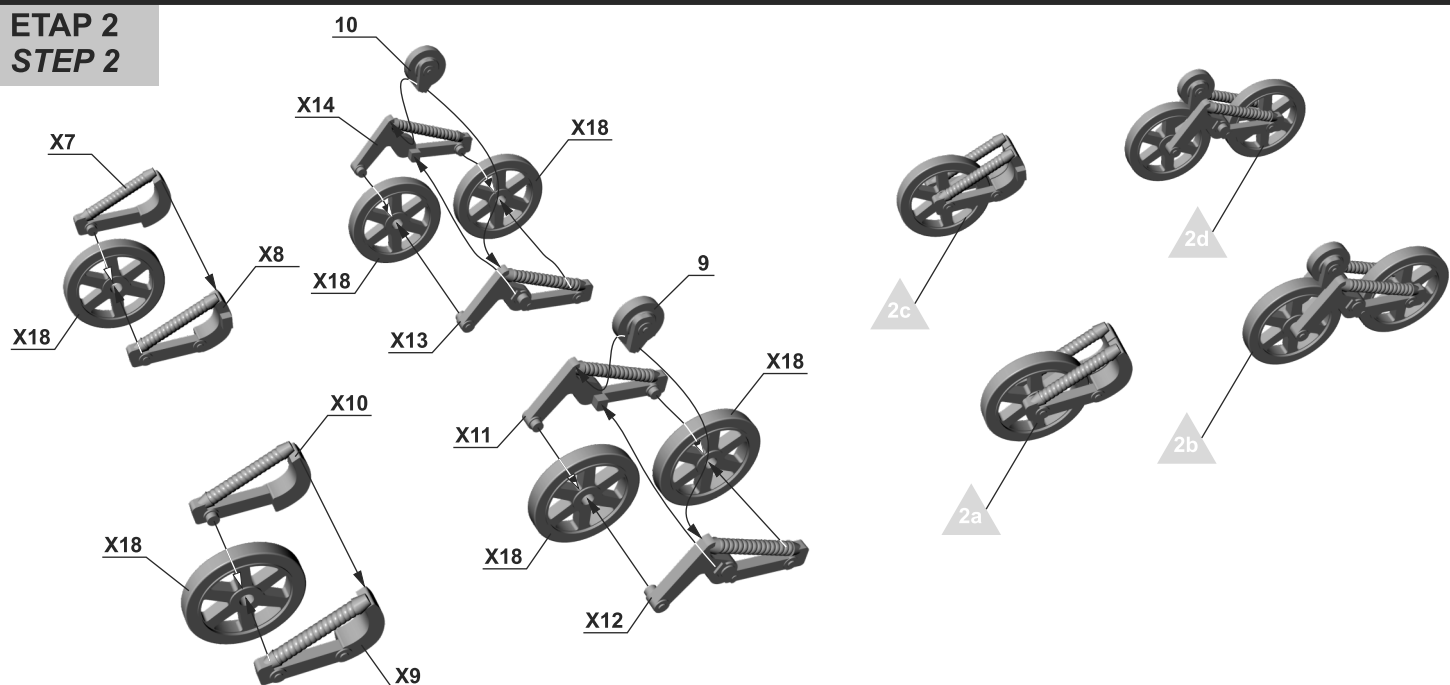

**ETAP 3  
STEP 3**

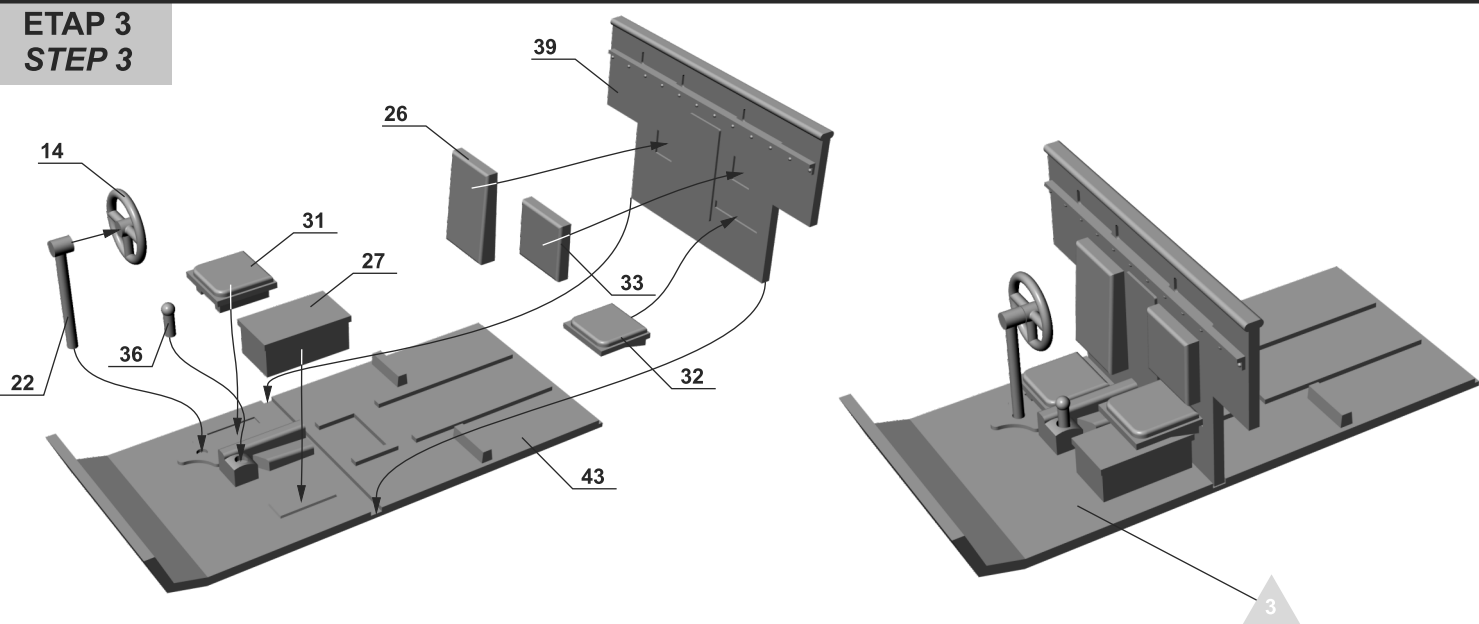

**ETAP 4  
STEP 4**

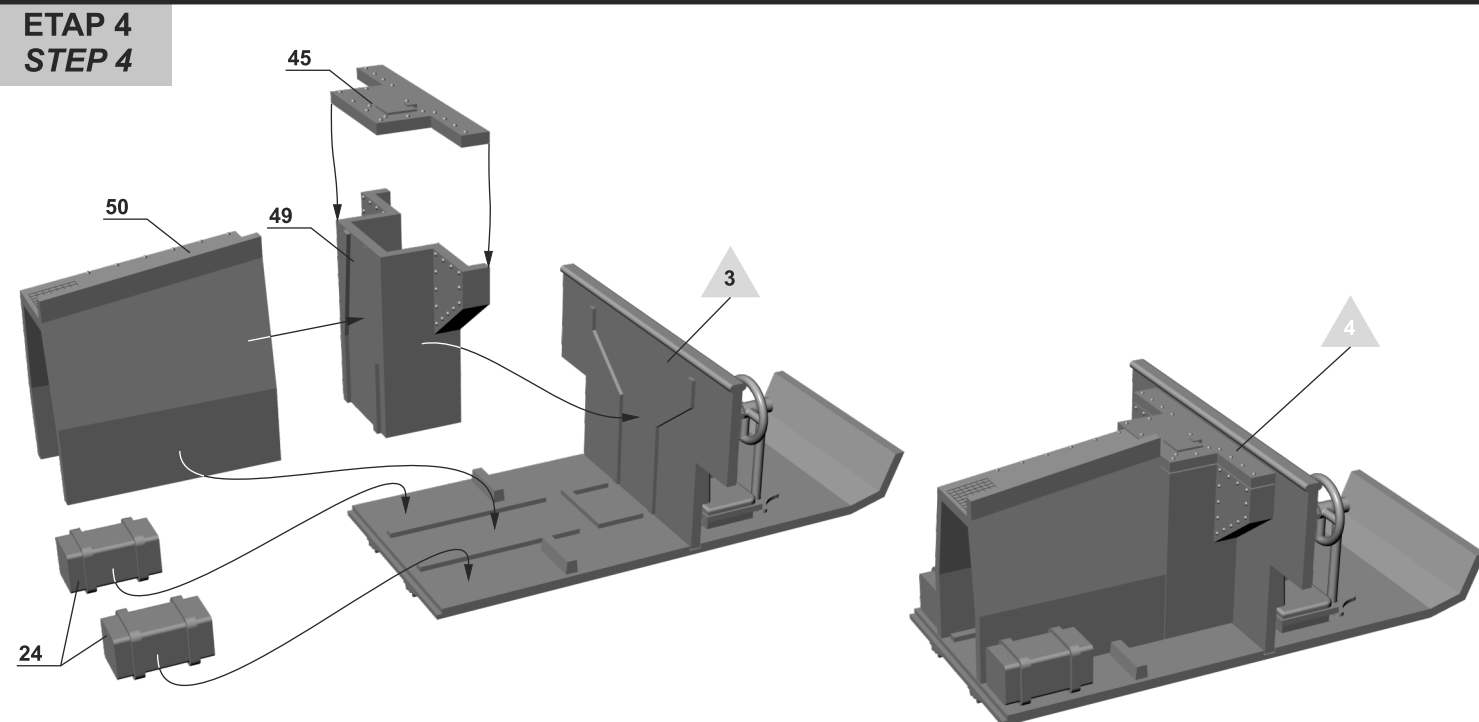

**ETAP 5  
STEP 5**

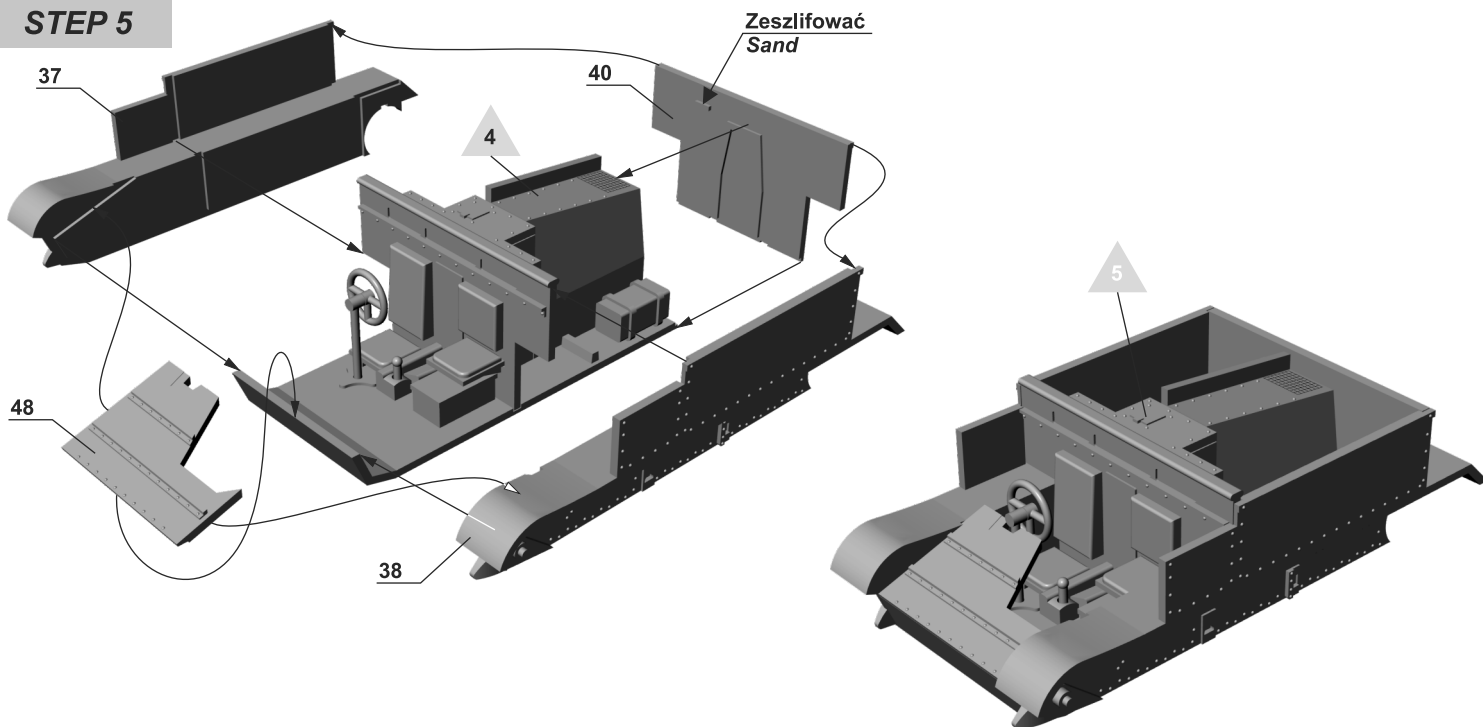

**ETAP 6  
STEP 6**

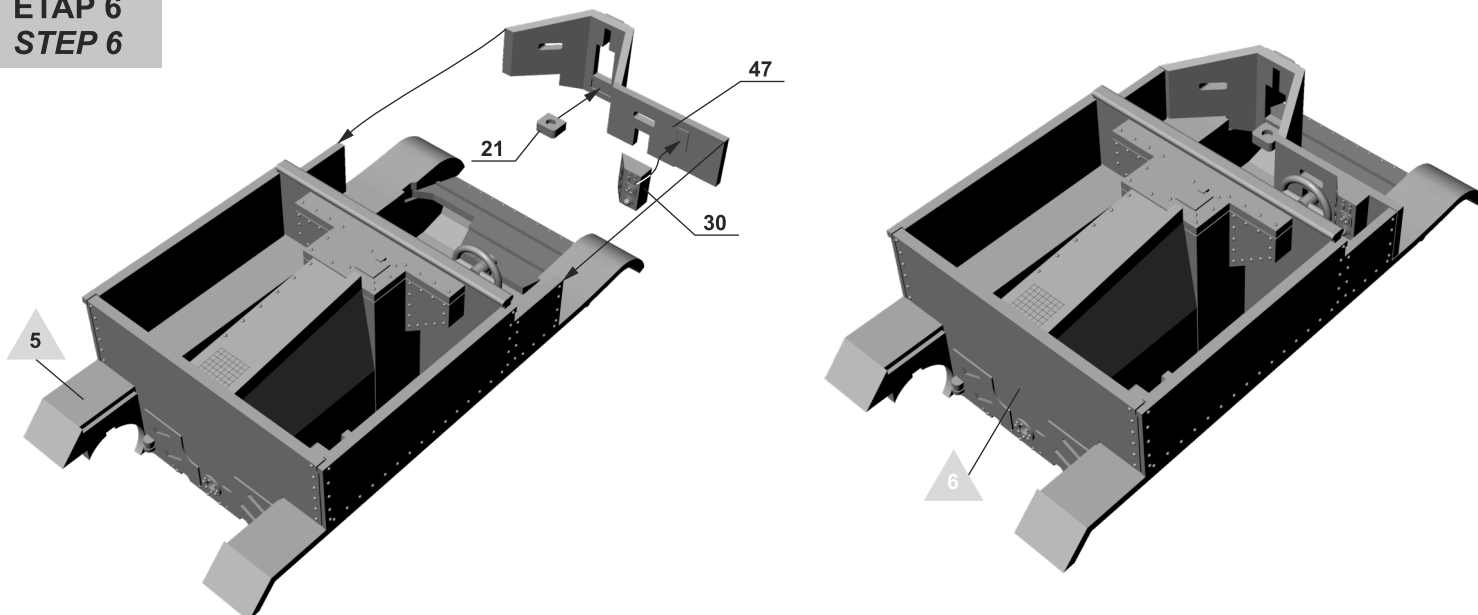

**ETAP 7  
STEP 7**

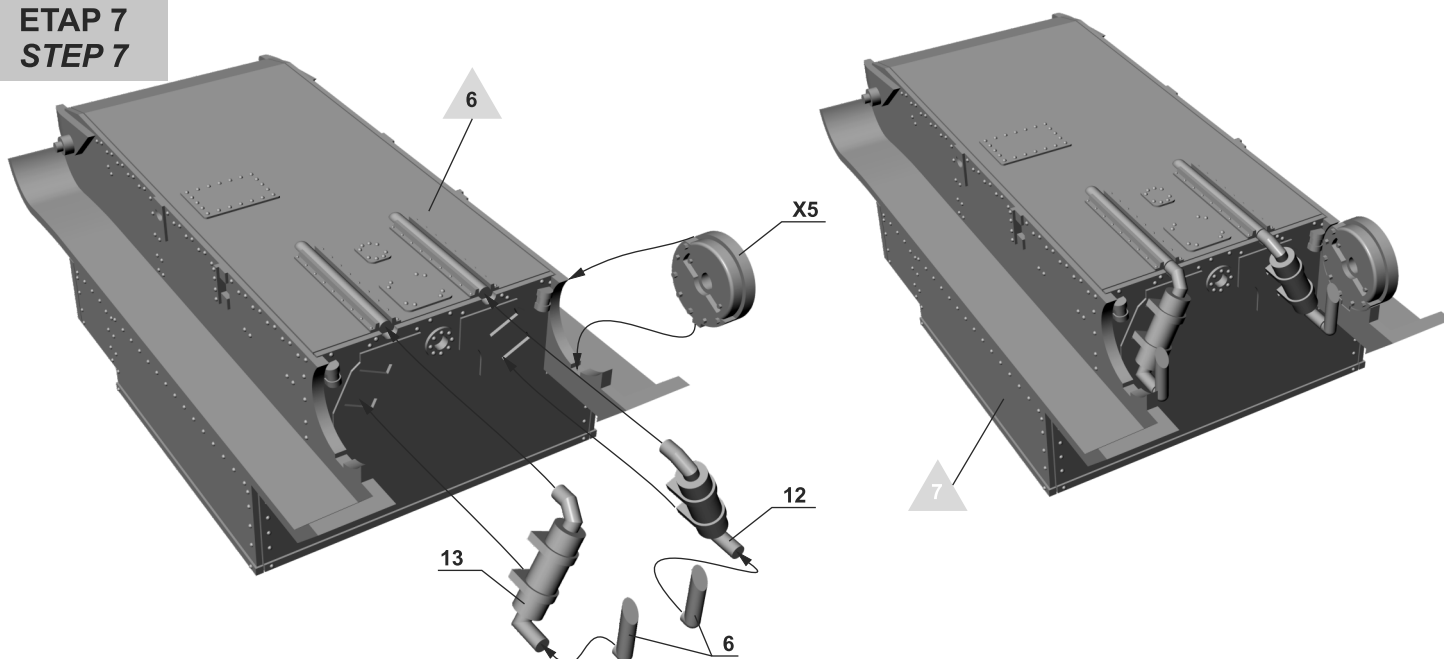

**ETAP 8**  
**STEP 8**

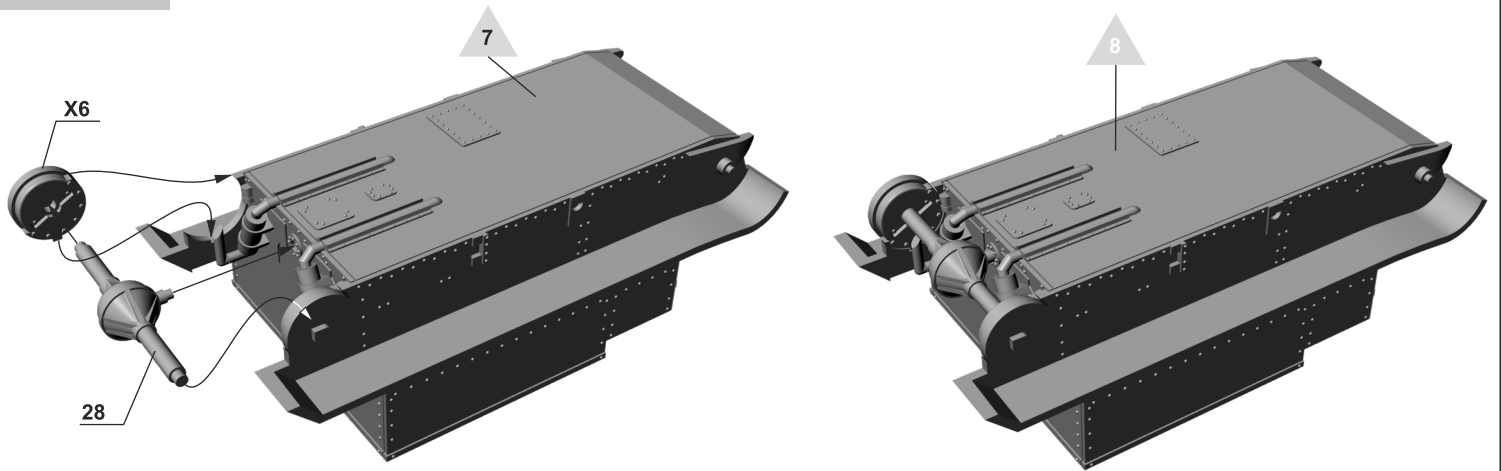

**ETAP 9**  
**STEP 9**

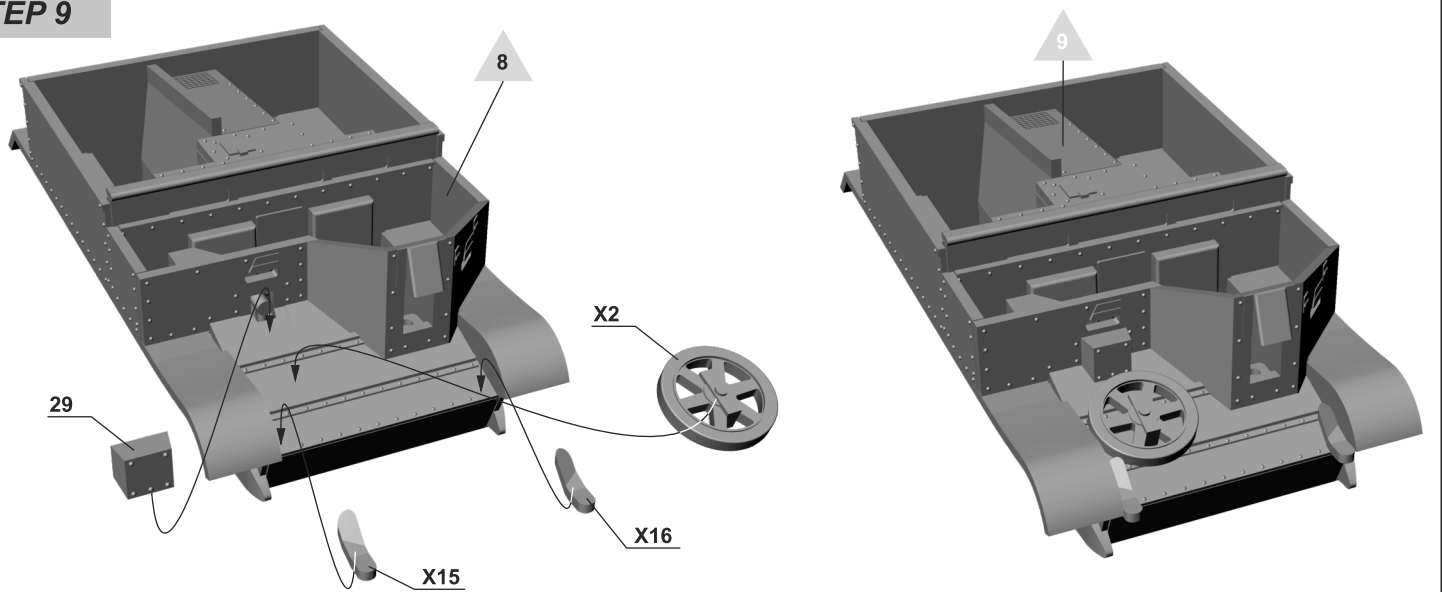

**ETAP 10**  
**STEP 10**

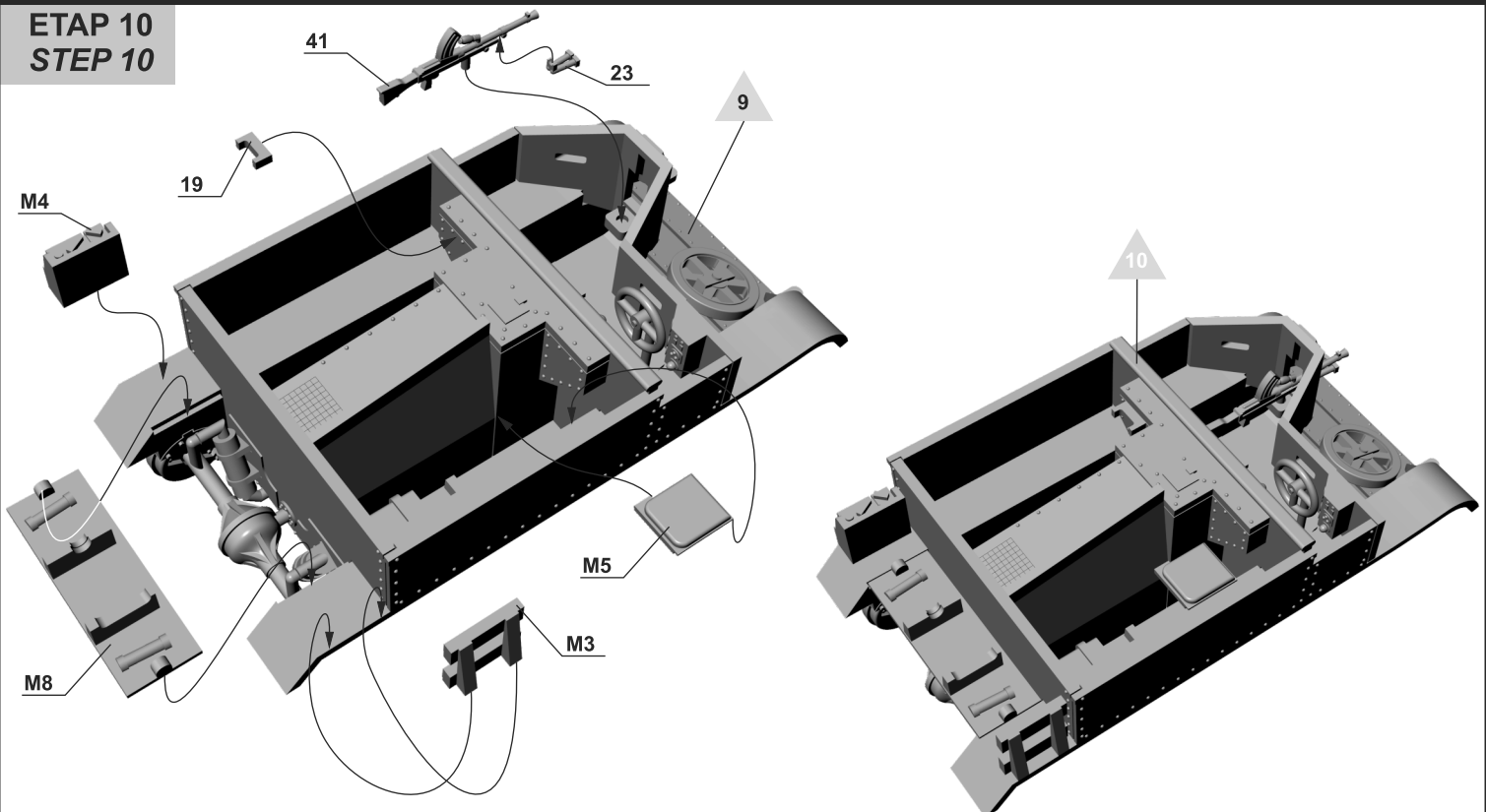

ETAP 11  
STEP 11

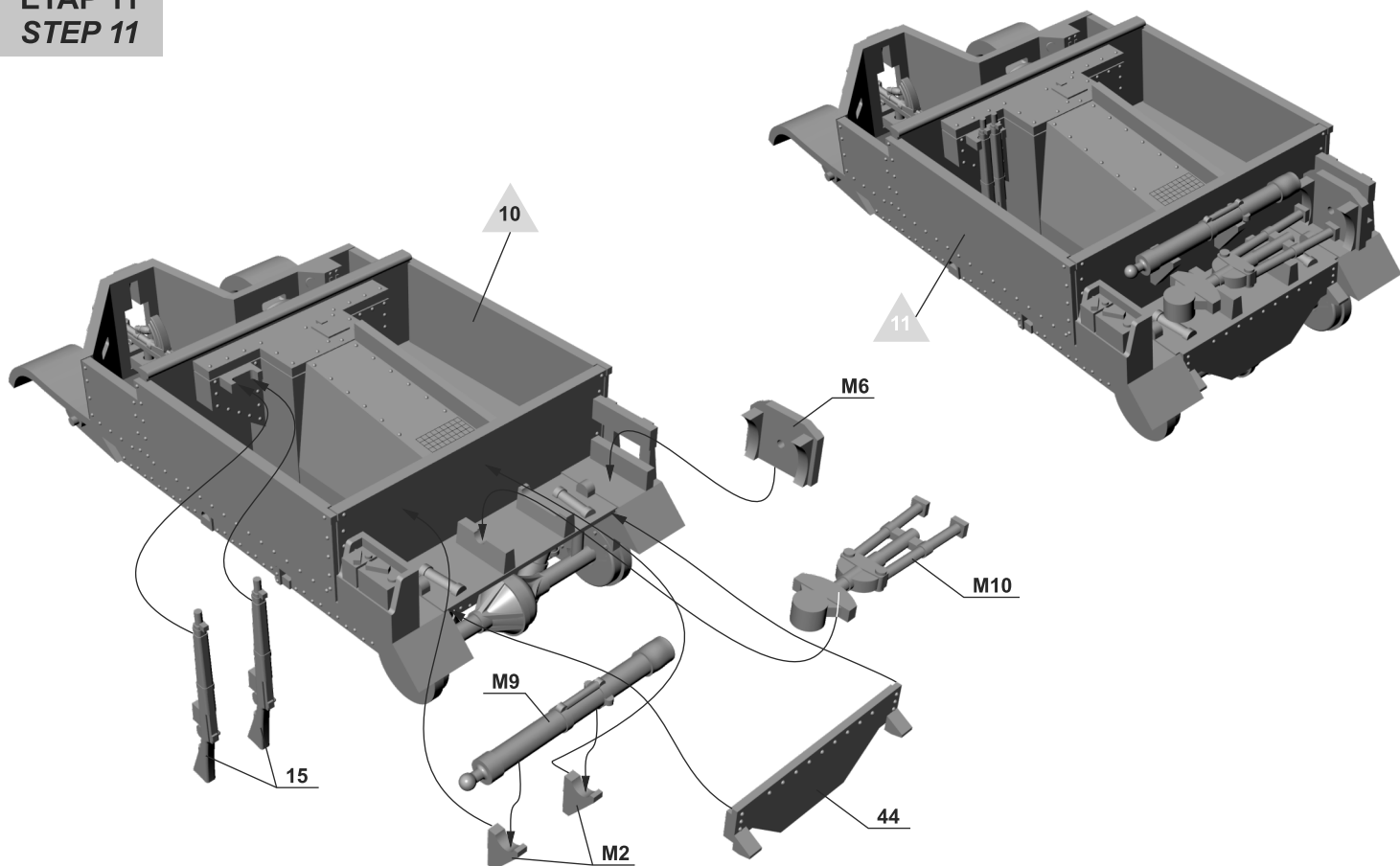

ETAP 12  
STEP 12

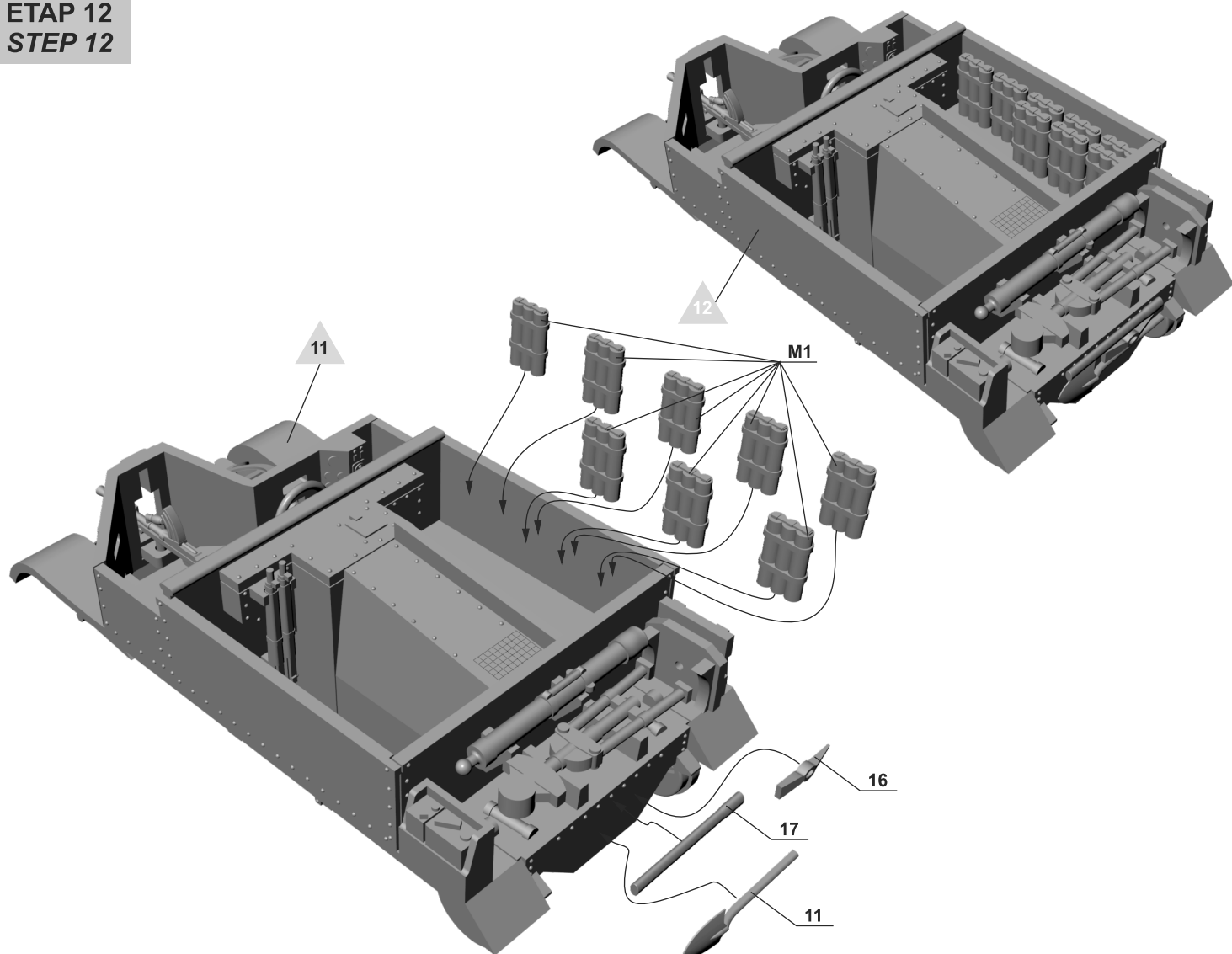

**ETAP 13**  
**STEP 13**

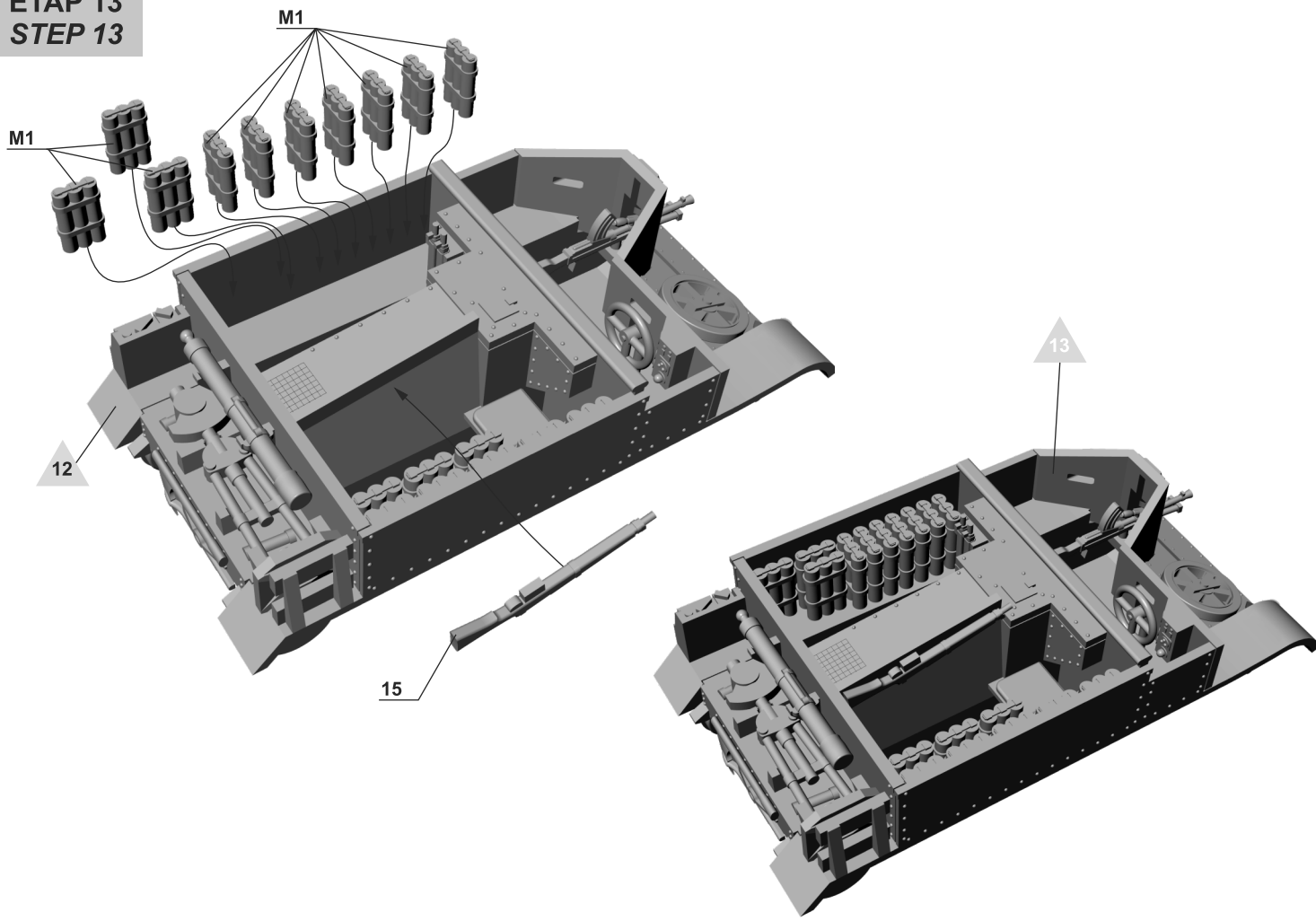

**ETAP 14**  
**STEP 14**

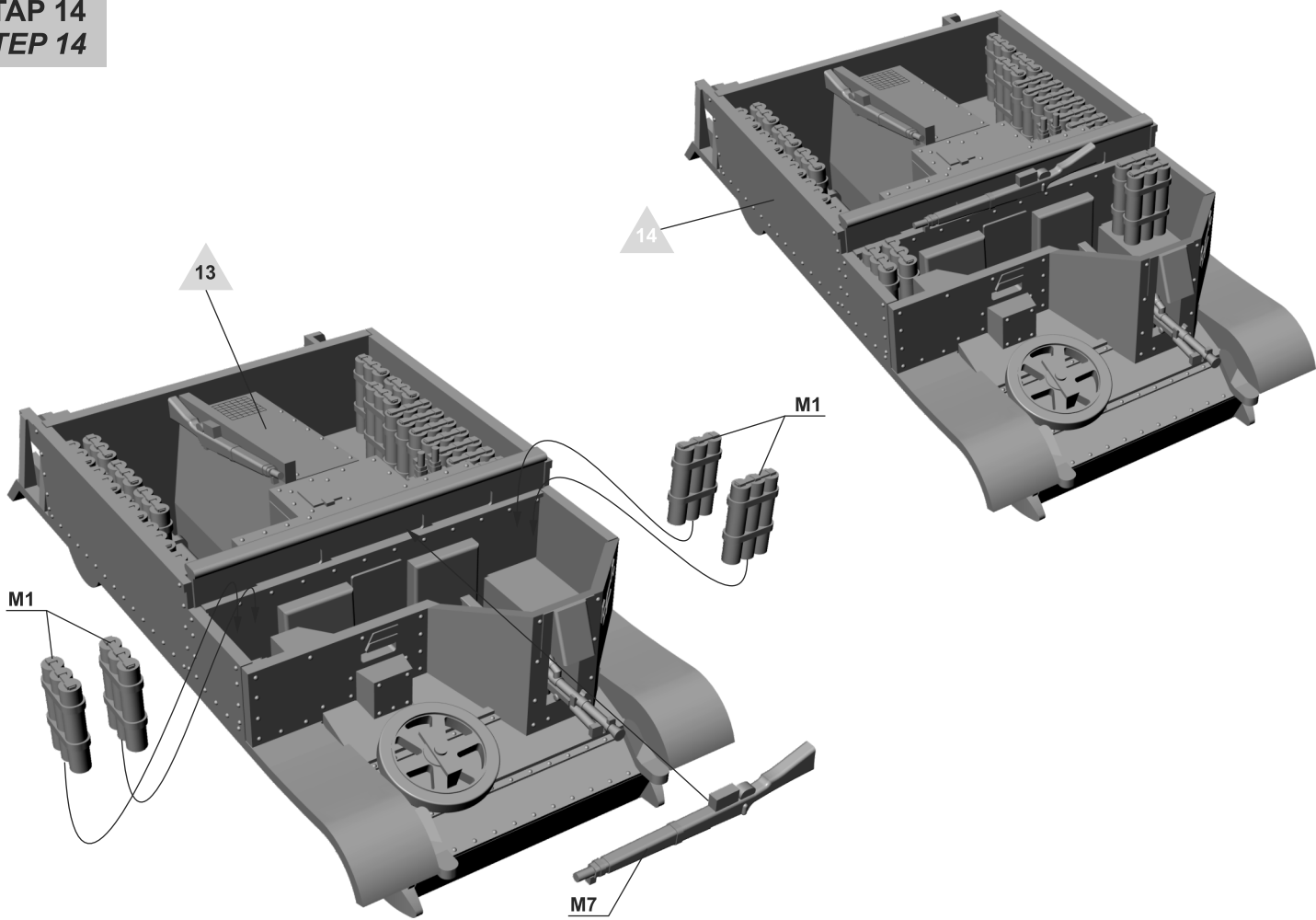



**ETAP 15  
STEP 15**

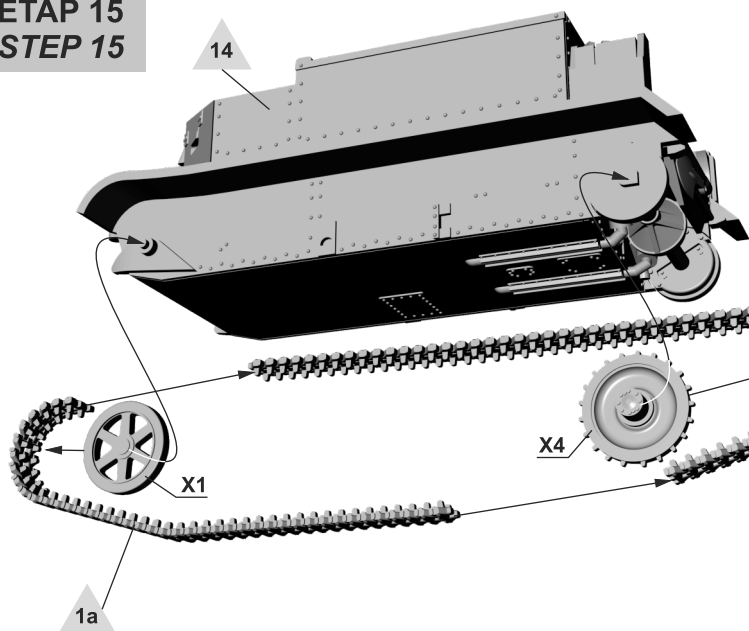

Czynności powtórzyć dla drugiej strony modelu używając części X1 i X3 oraz drugiej gąsienicy.  
Make the same on other side of model using X1 and X3 parts and second track.

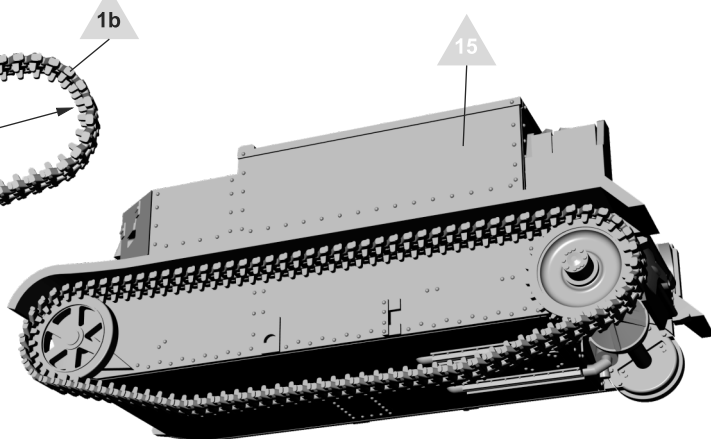

Sprawdzić pasowanie przed przyklejeniem. Jeśli potrzeba dodać ogniwa.  
Check fitting before gluing. Add track links if needed.

**ETAP 16  
STEP 16**

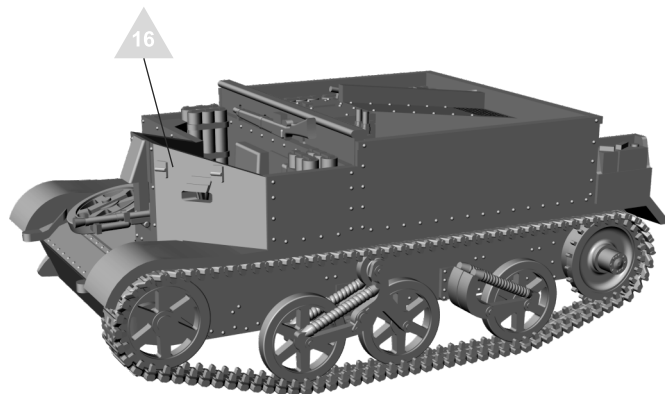
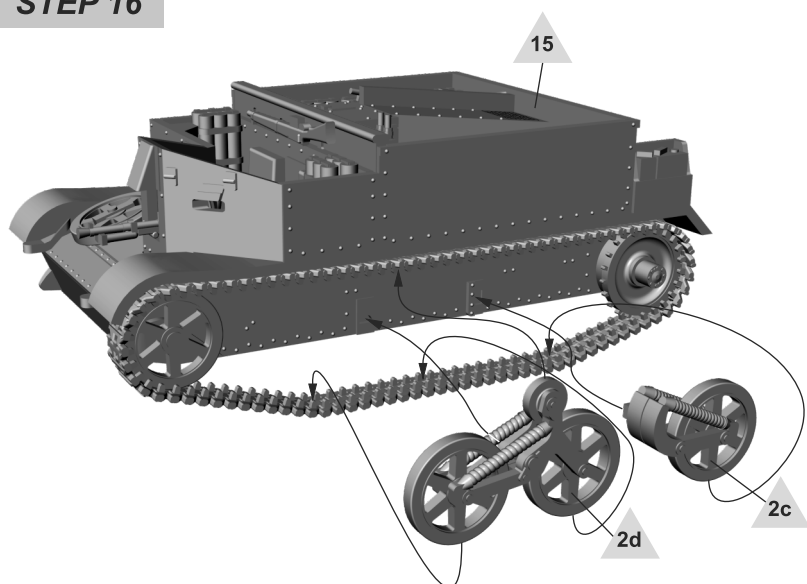

Czynności powtórzyć dla drugiej strony modelu używając części 2a i 2b z Etapu 2.  
Make the same on other side of model using 2a and 2b parts from Step 2.

**ETAP 17  
STEP 17**

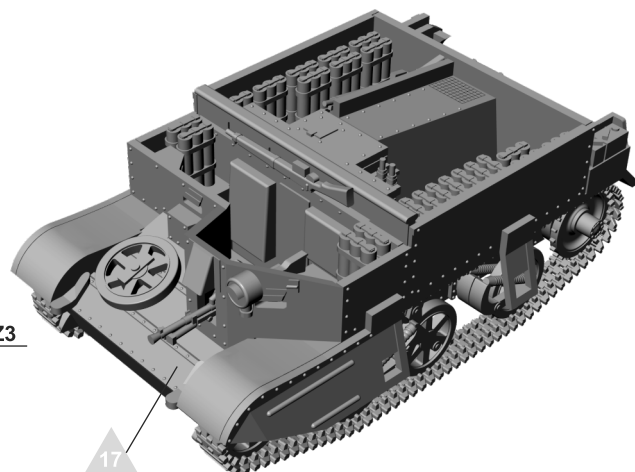
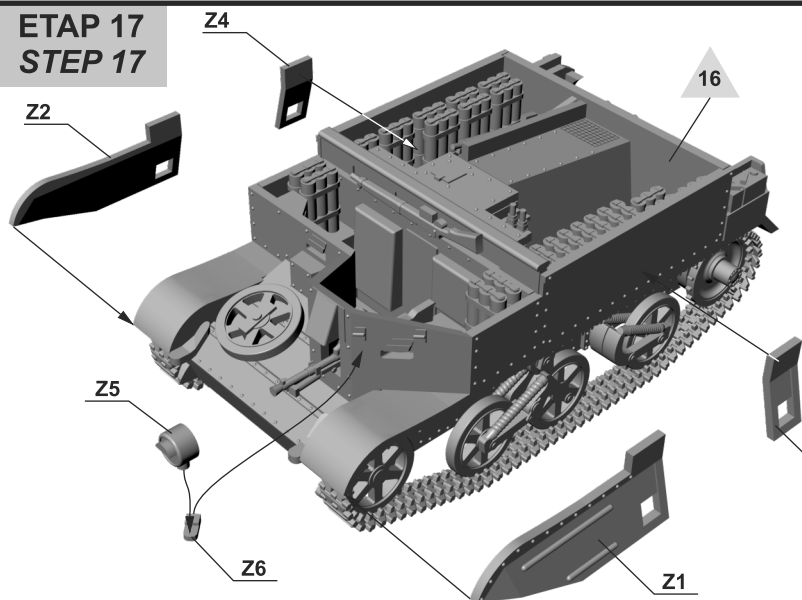

WYKONANY MODEL  
FINISHED MODEL

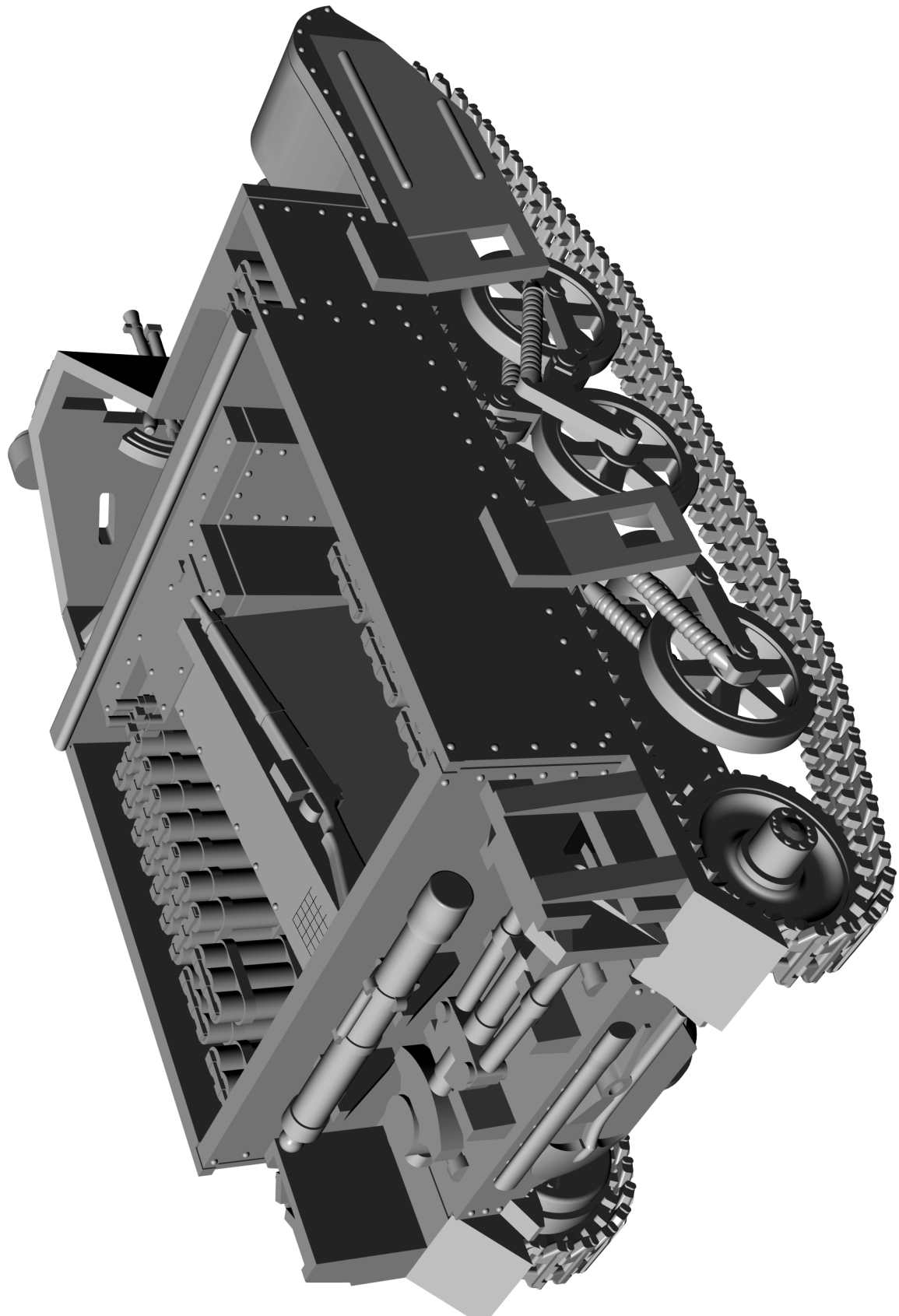

**MALOWANIE I KALKOMANIE**  
**COLOURS AND DECALS**

T 228174 z szwadronu dowodzenia 25. Pułku Ułanów Wielkopolskich 5. Kresowej Dywizji Piechoty  
 Włochy 1945  
 T 228174 from headquarters company of 25th Greater Poland Uhlan Regiment Polish 5th Kresowa  
 Infantry Division  
 Italy 1945

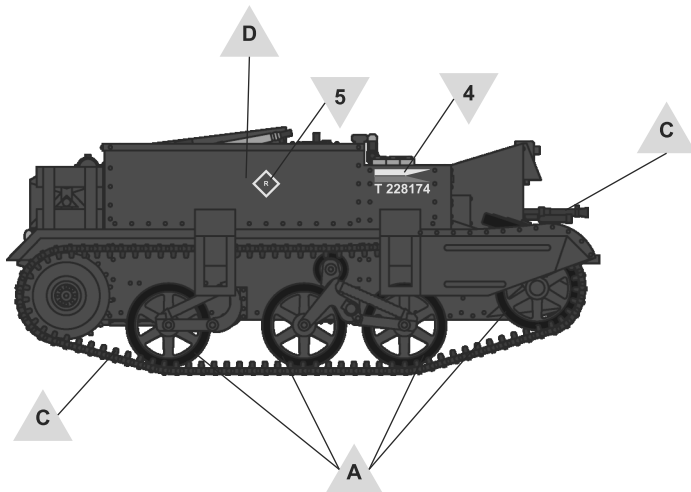
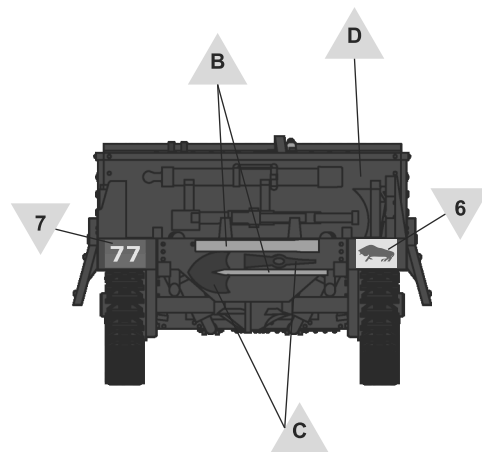
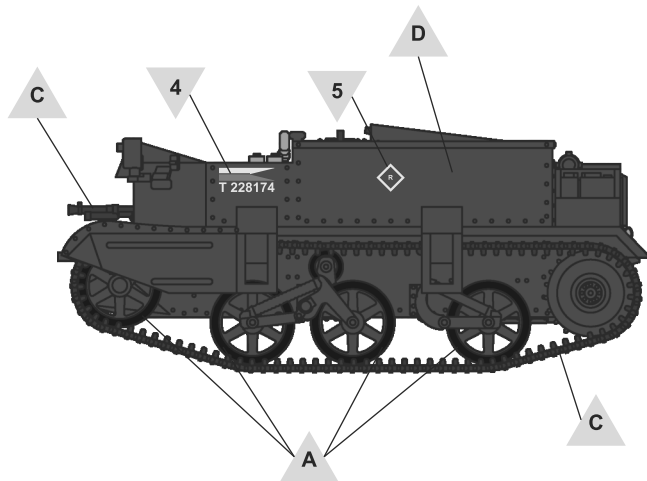
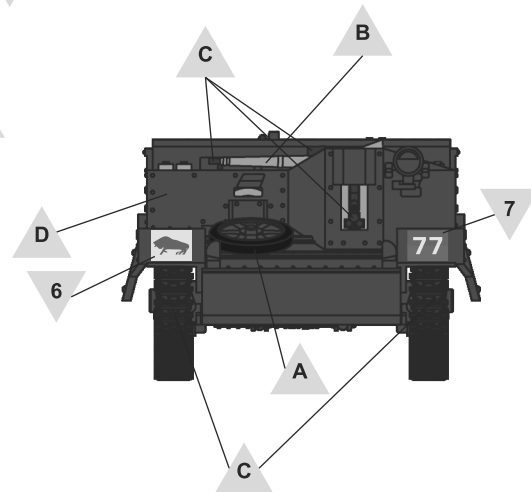
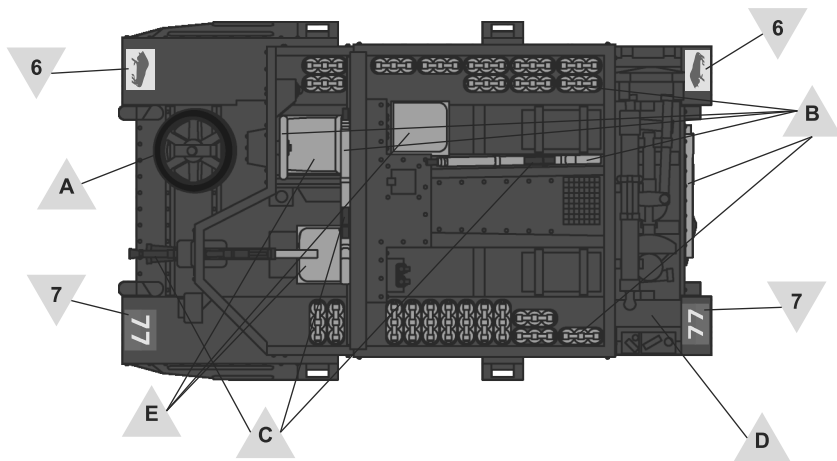

**MALOWANIE I KALKOMANIE**  
**COLOURS AND DECALS**

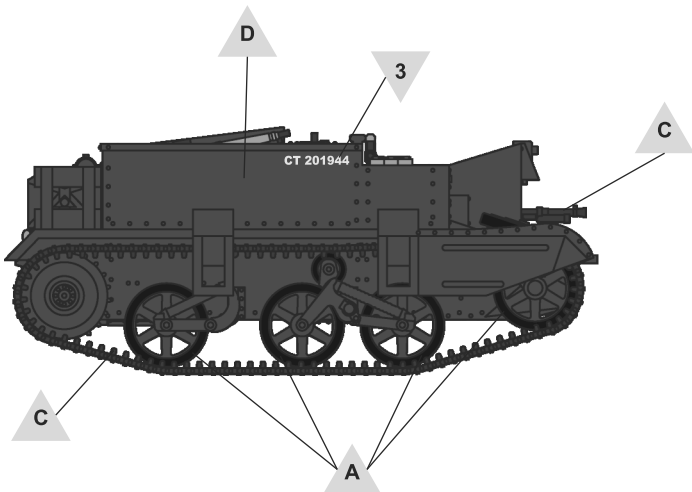
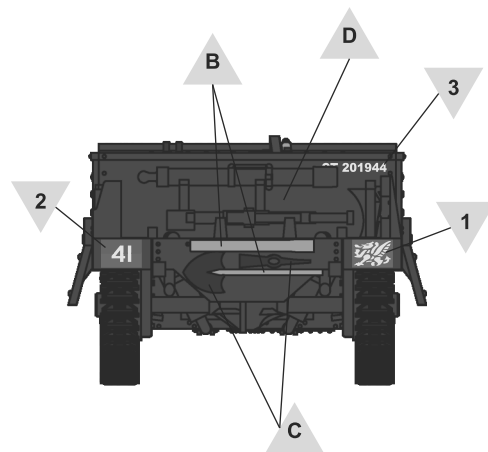
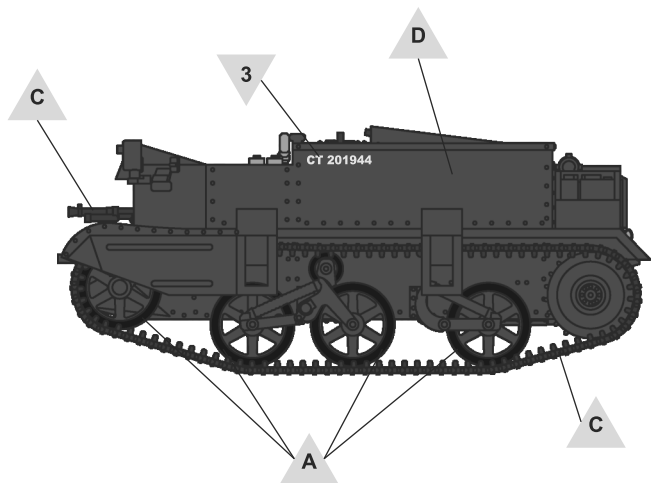
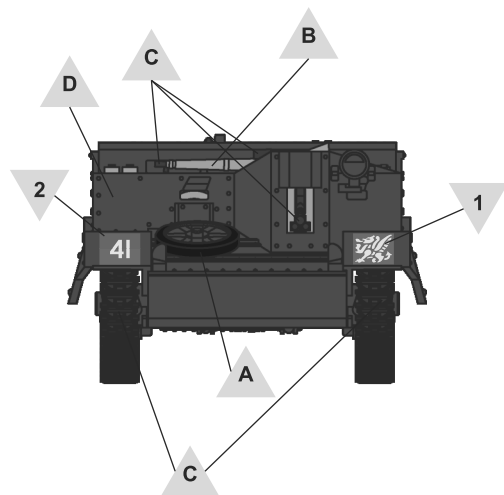
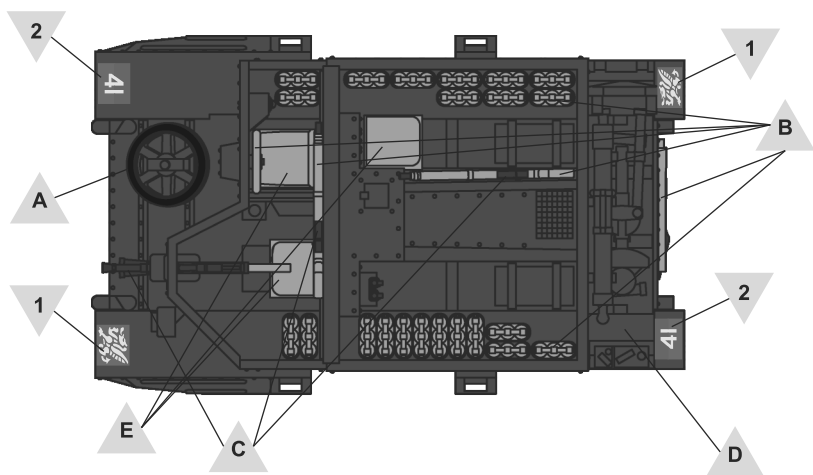

CT 201944 z 43. Pułku Rozpoznawczego 43. (Wessex) Dywizji Piechoty  
 Operacja "Market Garden" Holandia, wrzesień 1944  
 CT 201944 from 43th Reconnaissance Regiment 43th (Wessex) Infantry Division  
 Operation "Market Garden" Holland, September 1944